

High-Precision Tuning Fork
Carat Balance

CT-600CE Series

Operation Manual

IMPORTANT

- To ensure safe and proper use of the balance, please read this manual carefully.
- After reading this manual, store it in a safe place near the balance, so you can review it as needed.

VIBRA

SHINKO DENSHI CO., LTD.

PREFACE

Thank you for purchasing a CT-600CE Series electronic balance. This is a precision instrument equipped with exacting mechanisms in a compact body. The balance is easy to operate and features user-friendly keys. Furthermore, the large liquid-crystal display provides excellent visibility, and the instrument's high speed and stability—intrinsic to a tuning fork design—help boost operational efficiency.

Before using the balance, please check that the following items have been included in the package.

Should you find any missing parts, please contact your local dealer or our marketing division at once.

(1) Main unit of balance

(2) Measurement pan

(3) Pan base

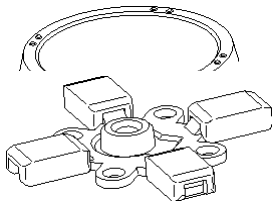

(4) AC adaptor

(5) DIN5P plug set

(6) Operation manual

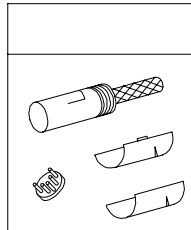
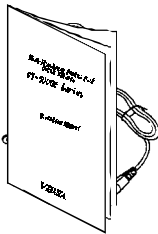

(7) For More Precise Measurements



CONTENTS

1. Precautions on the Use	2
2. Names of Component Parts	
2.1 Main Unit	5
2.2 LCD Indicators and Operating Keys	6
3. Basic Operations	
3.1 Installation	8
3.2 Operation Check	9
3.3 Operation for Tare Subtraction	10
4. Functions	
4.1 Setup and Checking of Functions	12
4.2 Description of Functions	13
4.3 Interface Section	14
5. Switching Function for Units of Measurement	15
6. Calibrating the Balance	17
7. Input/output functions	
7.1 Terminal Numbers and Functions	19
7.2 Connection between Balances and Personal Computers	20
7.3 Interface Specifications	21
7.4 Output Data	21
7.5 Input Commands	23
8. Operating the Balance with the Battery (CT-600CE)	25
9. Operating the Balance with the Dry Cell Battery (CT-600DBCE)	26
10. Removing the Windshield	27
11. Troubleshooting	28
12. Specifications	29
13. Conversion Table of Units	30

1. Precautions on the Use

- This Section "Precautions Relating to Use" sets forth precautionary notes that the user should observe in order to prevent physical injury to the user and/or damage to property.

The nature of problems that may result in the event of improper operation, and consequential effects on the quality and performance of the balance, are indicated under the two categories of "Caution" and "Recommended," and explained using symbols.



CAUTION

This symbol indicates a risk of injury or property damage if the balance is used improperly. Be sure to observe these notes to ensure safe use of the balance as the improper use may cause serious results.

RECOMMENDED

This term indicates steps that the user should take to ensure the quality and reliability of the balance.

Meanings of Symbols Each symbol is accompanied by an instruction.



Mandatory Symbol:

Indicates a "mandatory" action that should be executed without fail.



Check Level



Prohibitive Symbol:









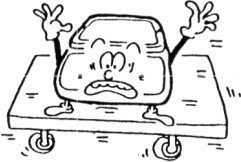

Indicates a "prohibited" action that must not be executed.



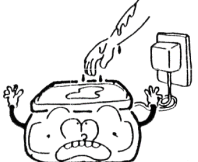

Do not Use

















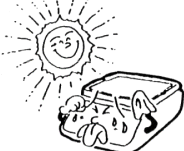

		<p>◆ Do not disassemble or modify the unit.</p> <ul style="list-style-type: none"> • Could cause malfunction or heat generation • Contact our Marketing Division or Technical Service Division.
		<p>◆ Only AC power (rated value) should be used.</p> <p>◆ Only use the dedicated AC adaptor.</p> <ul style="list-style-type: none"> • Use of other types of power or adaptors may result in heat generation or malfunction of the balance.
		<p>◆ Do not move the balance when a sample is loaded.</p> <ul style="list-style-type: none"> • The loaded sample may fall off the measurement pan and cause an injury.

 Do Not Use		<ul style="list-style-type: none"> ◆ Do not place the balance on an unstable base or use the balance in a location where it may be subjected to shock. • The loaded sample may fall off the measurement pan. • Accurate measurement may be rendered impossible.
 Do Not Drop		<ul style="list-style-type: none"> ◆ Do not lay the AC adaptor cable on the surface of the passage. • Somebody may trip on the cable, causing the balance to fall off, thereby causing injury and/or damage to the balance.
 Do not Handle with Wet Hands		<ul style="list-style-type: none"> ◆ Do not touch the AC adaptor or balance with wet hands. • Danger of electric shock
 Keep Dry		<ul style="list-style-type: none"> ◆ Do not use the balance in a location where it may be subjected to excess moisture. • Electric shock or short-circuiting could occur. • The balance may be corroded, with resultant malfunction.
 Do Not Leave Afloat		<ul style="list-style-type: none"> ◆ Do not use the balance with its adjusters lifted. • The balance will become unstable, preventing accurate measurement.
 Avoid Dust		<ul style="list-style-type: none"> ◆ Do not use the balance in a location where it may be subjected to excess dust. • Risk of explosion or fire • Short-circuit or lack of continuity may occur, leading to a malfunction of the balance.

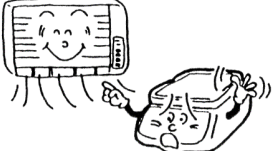
RECOMMENDED

 Calibrate Balance		<ul style="list-style-type: none"> ◆ Calibrate the balance after installation or relocation. • Measurement values may contain errors, preventing accurate measurement from being conducted.
---	---	--

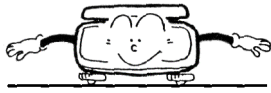
 Do Not Apply Force		<ul style="list-style-type: none"> ◆ Avoid applying excess force or impact to the balance. • Place the sample to be measured on the balance carefully to prevent breakage or malfunction.
 Do Not Use		<ul style="list-style-type: none"> ◆ Do not use the balance in a location where it may be subjected to abrupt changes in ambient temperature or humidity. • Accurate measurement may not be obtained. • Optimum operations occur when ambient temperatures range from 10°C to 30°C, and less than 80% relative humidity.
 Do Not Overload		<ul style="list-style-type: none"> ◆ Do not use the balance when [O - E r r] (Overloaded) is displayed. • Take down the loaded sample immediately to prevent breakage or malfunction.
 Do Not Use		<ul style="list-style-type: none"> ◆ Do not use the balance in a location where it is subject to direct sunlight. • The indications would be illegible. • An internal temperature increase in the balance may lead to inaccurate measurement.
 Unplug Adapter		<ul style="list-style-type: none"> ◆ If the balance is to be unused for an extended period of time, unplug the adaptor. • This conserves power and prevents deterioration.
 Do Not Use		<ul style="list-style-type: none"> ◆ Do not use volatile solvents for cleaning. • The body may be distorted. • To clean the unit of stains, use a piece of dry cloth or cloth soaked in a small quantity of neutral detergent.
 Do Not Use		<ul style="list-style-type: none"> ◆ Do not use the balance in a location where it may be subject to air from an air-conditioning unit. • Extreme changes in the ambient temperature may result in inaccurate measurements.
 Do Not Use		<ul style="list-style-type: none"> ◆ Do not use the balance on a soft floor. • When loaded with a sample, the balance may tip or move, preventing accurate measurements from being conducted.
 Check Level		<ul style="list-style-type: none"> ◆ Do not use the balance when it is tilted. ◆ An inclined balance is likely to produce errors, preventing accurate measurements from being conducted. Place the balance on a level surface.

2. Names of Component Parts

2.1 Main Unit

Front View

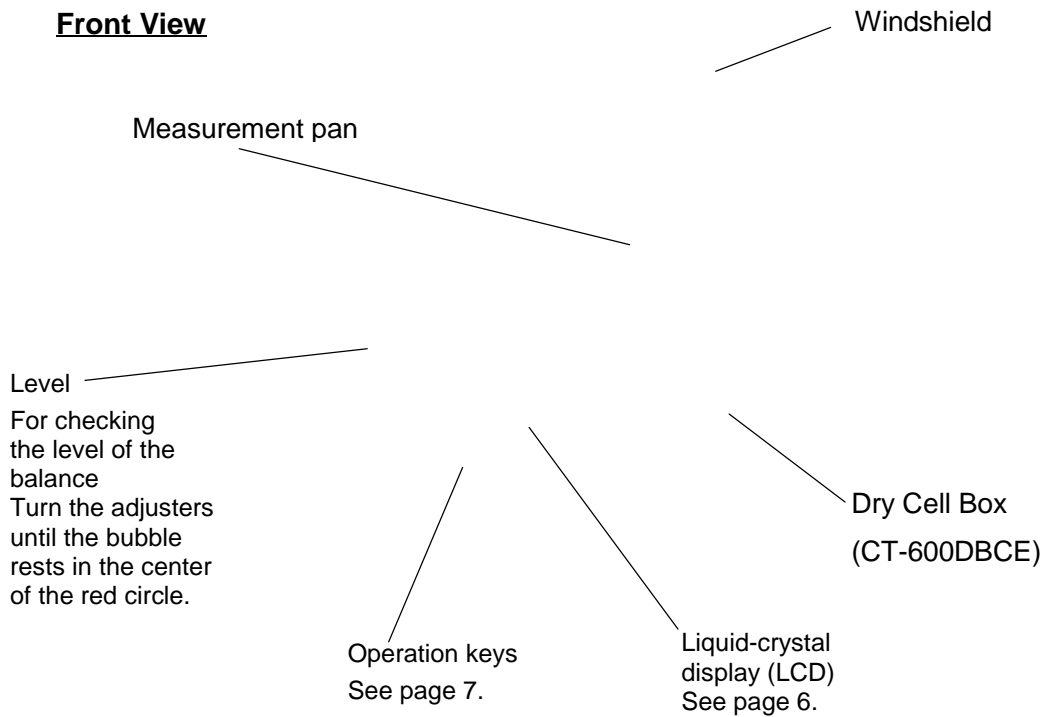



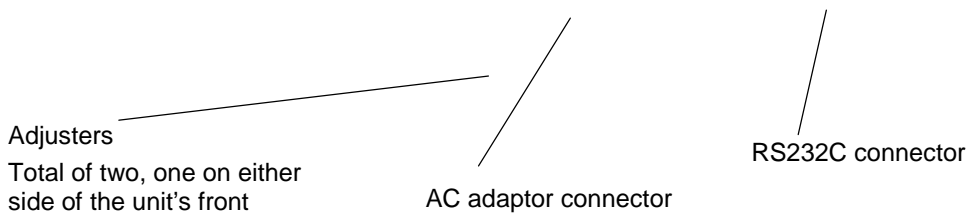

Rear view







2.2 LCD Indicators and Operating Keys

2.2.1 Symbols Displayed

Display	Description
ct	(ct) carat
	(g) gram
oz	(oz) ounce 1
lb	(lb) pound 1
oz t	(ozt) troy ounce 1
dwt	(dwt) penny weight 1
▶ (Lower right)	(▶ Lower right) grain 1
tl	(tl) tael(Hong Kong) 1
tl ▶ (Upper right)	(tl ▶ Upper right) tael(Singapore, Malaysia) 1
tl ▶ (Lower right)	(tl ▶ Lower right) tael(Taiwan) 1
mom	(mom) momme
to	(to) tola 1
	Display of the auxiliary scale interval
0	Zero point
NET	Tare being subtracted
	Indication of stable balance (If the light is off, the balance is unstable.)
	Balance powered up (Lights up when the power is turned off) or data transmitted
M	Display of set values from memory (If a value is flashing, it is being saved.)
CAL	Stays on and flashes while span adjustment is in progress.
	Bar graph
	It stays on [] when operated by rechargeable battery or dry cell battery. It flashes [] when the battery capacity becomes low. (Refer to page 25 or 26.) It does not show when powered by AC adaptor.

1 Can be set only for a model on which the lock switch is off.

2.2.2 Names and Functions of Operating Keys

Operating Key		Function	
	On/off key	Key to turn on/off the unit power	
	Print key	[Brief press]	initiates print or output.
	Set key	[Brief press]	sets function
	Function key	[Brief press]	toggle-switches the units to be displayed in succession (ct , , etc.).
		[Brief press]	selects an item when setting the function.
		[Continuous press]	invokes various functions.
		[Longer continuous press]	invokes span adjustment.
	Zero/Tare key	[Brief press]	resets the indication to zero when using zero-point setup or tare subtraction.
		[Brief press]	selects a function when operating the balance in the function mode.

3. Basic Operations

3.1 Installation

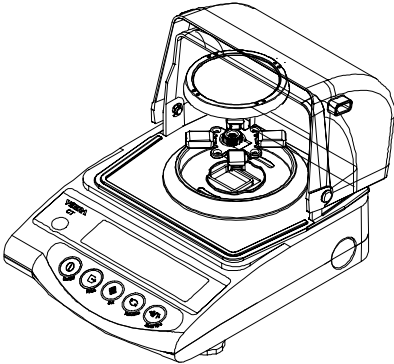
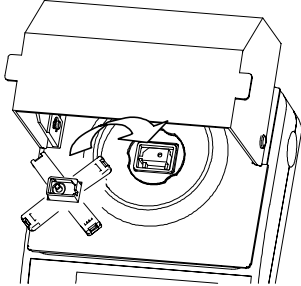
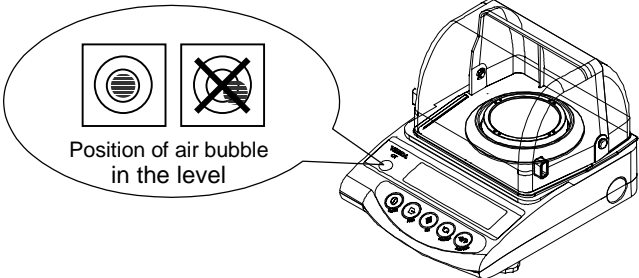
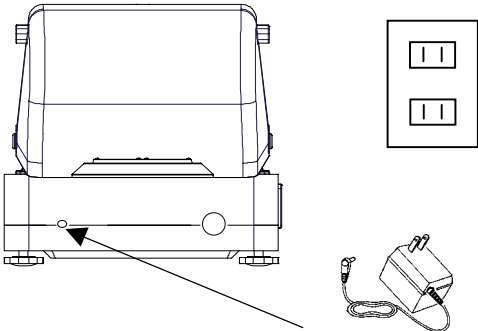
<p>1 Installation of the windshield and the weighing pan</p> <div style="text-align: center; margin-top: 20px;">  </div>	<p>Refer to "Windshield Assembling" attached in the box.</p> <p>First, mount the pan base on the main unit of the balance and place the measurement pan on top of it.</p> <p>Be sure to mount the pan base in the correct direction, as illustrated below.</p> <div style="text-align: center; margin-top: 20px;">  </div>
<p>2 Securing the exact level of the balance</p> <div style="text-align: center; margin-top: 20px;">  <p style="font-size: small;">Position of air bubble in the level</p> </div>	<p>Turn the adjusters until the bubble rests in the center of the red circle on the level. The adjuster is located on either side at front.</p>
<p>3 Connecting the AC adaptor</p> <div style="text-align: center; margin-top: 20px;">  </div> <p style="margin-top: 20px;"><Caution> If the balance has the battery installed, refer to "8. Operating the Balance with the Battery," on page 25</p>	<p>3' Installing the dry cell battery (CT-600DBCE)</p> <p style="text-align: center; margin-top: 20px;">Can be operated with AC adaptor, too.</p>

3.2 Operation Check

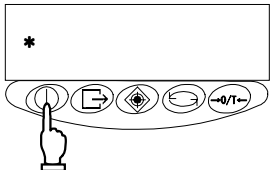
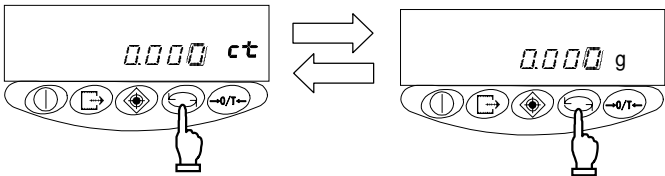
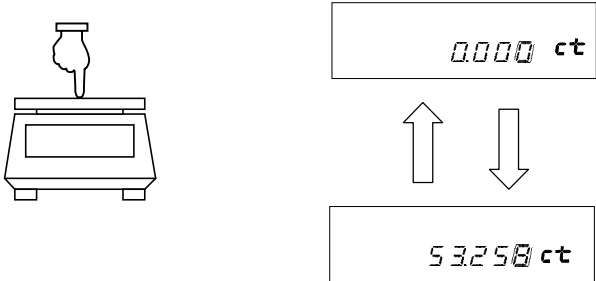
<p>1 Turning on the power</p> 	<p>When the balance has the AC adaptor connected, it displays [*]. Pressing the On/Off key The display section lights up, and the balance is ready for operation.</p>
<p>2 Checking the display</p>	<p>Check to see if the display has any missing indications or unlit parts. A few seconds after startup, the indication is reset to zero.</p>
<p>3 Switching the measurement mode</p> 	<p>Press the Function key. Each time the key is pressed, the unit of measurement changes, as indicated.</p> <p>The balance is shipped from the factory with the following switching sequence: [ct] → [g] → [ct] → . . .</p>
<p>4 Verifying changes in the read-out indicator</p> 	<p>Press the measurement pan lightly and make sure that the read-out indicator changes. Also, ensure that the read-out indicator is reset to zero when you release your hand.</p>

3.3 Operation for Tare Subtraction

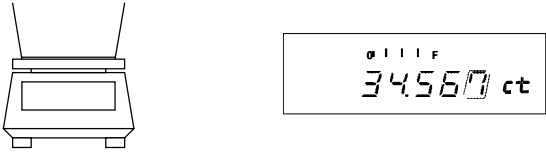
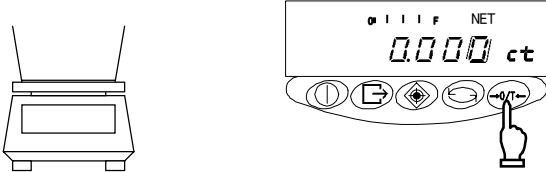
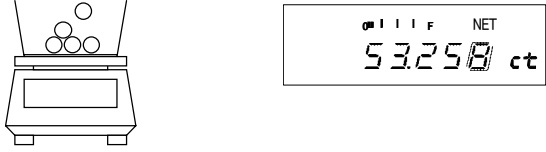
<p>1 Place the tare (container) on the balance.</p> 	<p>As you place the tare, the balance indicates its weight.</p>
<p>2 Reset read-out indication to zero.</p> 	<p>Press the Zero/Tare key. The tare is subtracted and the balance indicates zero.</p>
<p>3 Load the sample to be weighed.</p> 	<p>The balance will now indicate only the weight of the sample loaded in the tare.</p>

Weighing only the weight of an added sample

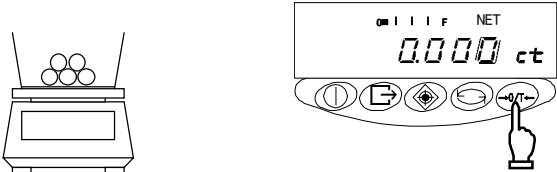
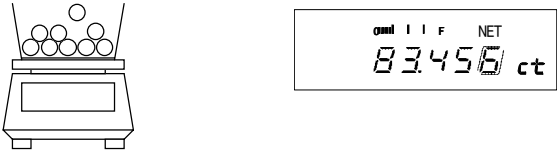
<p>4 Resetting the indication to zero</p> 	<p>Press the Zero/Tare key. The total weight of the sample loaded on the measurement pan is indicated as zero.</p>
<p>5 Adding samples to be measured</p> 	<p>The balance indicates only the weight of an added sample. When the weight (of a sample) currently loaded on the measurement pan is reset to zero with the Zero/Tare key, as mentioned above, only the weight of the sample will be measured.</p>

Key Points of the Procedure

- After the balance is switched off, there is still enough current to display [*]. This indicates that the AC adaptor is connected to an electrical outlet, but that the balance is turned off. When the balance is switched on again, [*] will disappear.
If the balance is running on batteries and the unit is switched off, the display does not display [*].

- The bar graph shows the current load status with respect to the capacity of the balance. The nearer the [F] mark draws, the smaller the measurable weight becomes.

Even when the display currently indicates zero with the tare subtracted, the weight corresponding to the subtracted tare is indicated on the bar.

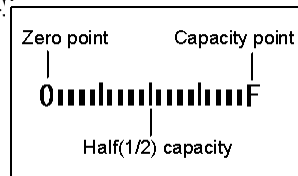

- When the balance remains stable, the stability indicator [] remains on. If the balance becomes unstable, the stability indicator [] will disappear. When a displayed value flickers or the stability mark flashes on and off, it is likely that the balance is being affected by wind or other vibrations. Use the windshield or vibration dampers to protect against such adverse effects.

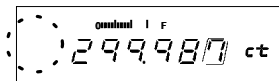

Unstable



Stable

- When the read-out indicator is reset to zero or the tare is subtracted, the balance indicates zero this way: [→ 0 ←].

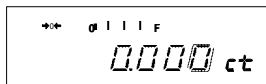

* If the indication deviates from the true zero point by 1/4 of a graduation or less, [0] disappears.

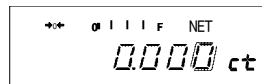

* If zero is set or the tare is subtracted, the balance indicates zero, and [NET] lights up.



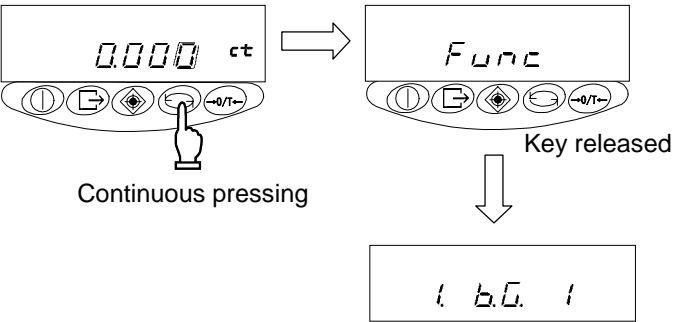
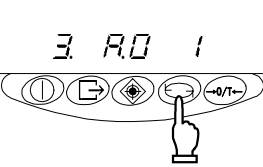
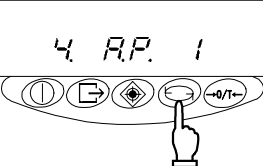
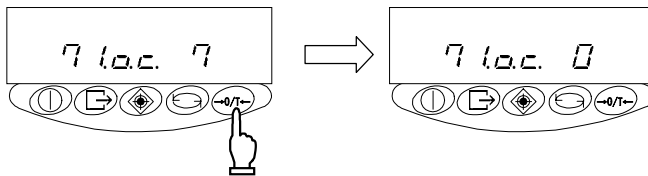
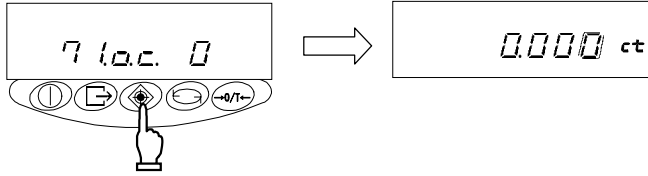

- When the tare is subtracted, the measurable range is reduced.
Measurable Range = Capacity - Tare Weight
- If [E r r] appears when a sample is loaded, the measurable range has been exceeded.
- The measurement unit that is activated when the balance is switched on will be the one that was active when last switched off. For example, if the balance was switched off in gram, this gram unit will be reactivated the next time the balance is switched on.
- To print data on the balance, set "Output Control (7 (o.c.))" to [2], [4], [5], or [7], so that only stable data will be printed (see "4.3 Interface Section" on page 14).

4. Functions

4.1 Setup and Checking of Functions

<p>1 Invoking the function</p>  <p>Continuous pressing</p> <p>Key released</p>	<p>Press and hold down the Function key until the indicator changes to "Func," then release the key.</p> <p>The function setup mode is activated, and the first item, [1. b.G. 1] (Bar graph) appears. (See "4.2 Description of Functions" on page 13.)</p>
<p>2 Selecting the next item</p> 	<p>Press the Function key.</p> <p>The indication changes to the next item, [3. RD 1] (Auto zero).</p>
<p>3 Selecting an item</p> 	<p>Pressing the Function key advances the function items at the rate of one item per press.</p>
<p>4 Changing the content of an item</p> 	<p>Select the item to be changed with the Function key.</p> <p>Each press of the Zero/Tare key changes the digit on the right end. Select the desired one.</p>
<p>5 Terminating the function selection</p> 	<p>Press the Set key.</p> <p>The balance terminates the function setup and returns to measurement mode.</p>

4.2 Description of Functions

Item	Set Value	Description	
Bar graph display	1 <i>b.G.</i>	0 Disable	
		1 Enable	
Auto-zero (zero-tracking)	3 <i>R.O.</i>	0 Disable	
		1 Enable	This function automatically sets the zero point exactly to zero to prevent slight deviations.
Auto power-off	4 <i>R.P.</i>	0 Disable (balance operates continuously)	
		1 Enable (balance powers off in approximately three minutes)	This function is available only when the balance is battery-operated.
Response speed	5 <i>r.E.</i>	0 Measurement by consecutive weighings.	
		1 Fast	
		2 	
		3 	
		4 Slow	
Stability parameters	6 <i>S.d.</i>	1 Wide (mild)	
		2 	
		3 	
		4 Narrow (strict)	
Interface	7 <i>I.F.</i>	0 Disable input/output	
		1 Six-digit numeric format	[4.3 Interface section]
		2 Seven-digit numeric format	
Setup of units of measurement to be displayed Register selected measuring units with Function key.	8 <i>U.S.</i> 85 <i>U.S.</i> 1	2 0 1 [g]	
		1 0 2 [ct] (ct)	
		1 5 [oz] (oz) 2	
		1 6 [lb] (lb) 2	
		1 7 [oz t] (ozt) 2	
		1 8 [dwt] (dwt) 2	
		1 9 [▶ Lower right] (grain) 2	
		1 A [tl] (tl_Hong Kong) 2	
		1 b [tl ▶ Upper right] (tl_Singapore, Malaysia) 2	
		1 C [tl ▶ Lower right] (tl_Taiwan) 2	
		1 d [mom]	
		1 E [to] (to) 2	
3-5 0 0 Unit not set			

Items marked are the default factory settings.

1 ~ 5: default settings [8 *U.S.*] ~ [85 *U.S.*]

1 [00] cannot be set at [8 *U.S.*].

2 Can be set only for a model on which the lock switch is off.

Display of the auxiliary scale interval	71 A I	0	Disable
		1	Enable (0 is the auxiliary scale interval.) Note: The auxiliary-scale-interval place does not represent a verification scale interval. Use it only as a reference value.
Output format while the auxiliary scale interval is displayed	72 P r F 3	1	No output is made while the auxiliary scale interval is displayed.
		2	Output is made even while the auxiliary scale interval is displayed.
		3	Output is made with “/” added to the left of the auxiliary-scale-interval place.

3 Can be set only for a model on which the lock switch is off.

4.3 Interface Section

Displayed when [71 I.F. 0] is set to [1] or [2]

Item	Set Value	Description	
Output Control	71 I.O.C.	0	Stop output
		1	Output continuous at all times
		2	Output continuous if stable (stop output if unstable)
		3	Outputs once by pressing Print key (irrespective of whether stable).
		4	Outputs once if stable. Outputs if the balance is stable when a sample is loaded after the preceding sample has been removed and the balance indicated zero, or less.
		5	Outputs once if stable, and stops output when unstable. Even if the sample is not replaced, the balance is output once when it stabilizes next time (including the zero indication).
		6	Outputs once if stable, and outputs continuously when unstable. Even if the sample is not replaced, output of the balance stops when it stabilizes after being output once.
Baud Rate	72 b.L.	1	1200 bps
		2	2400 bps
		3	4800 bps
		4	9600 bps
Parity	73 P.R.	0	None
		1	Odd
		2	Even

denotes a factory-setting

The data interval in continuous output mode is 0.1 to 1 second. (The interval varies depending on weighting conditions and other factors.)

5. Switching Function for Units of Measurement

Pressing the **Function** key allows the user to switch the unit of measurement to [g], [ct], [%], and so on. During setup, a maximum of five different units can be registered for use in function setup mode.

5.1 Switching Units of Measurement

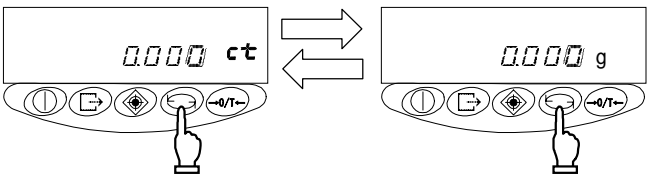
<p>Switching the units of measurement to be displayed</p> 	<p>Press the Function key. Each press advances through the units of measurement to be displayed.</p> <p>The balance is shipped from the factory with [ct] → [g] [ct] ...</p>
---	--

5.2 Setup of Units of Measurement

When values [8 1.5.u.] to [8 5.5.u.] are entered prior to use, the desired unit of measurement to be displayed can be chosen simply by pressing the **Function** key. For more information on the units of measurement that can be set here, please refer to “4.2 Description of Functions” on page 13.

Example: To change the default factory settings to pound units, use [8 3.5.u.] in the factory settings.

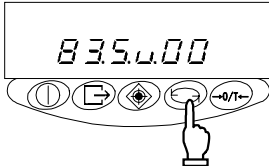
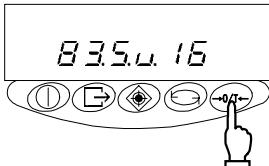
<p>1 Display the function item [8 3.5.u. 00]</p> 	<p>Press and hold down the Function key. Release the key as [F u n c] appears on the display. The function setup mode is now activated and the first item is displayed. Press the Function key several more times, until [8 3.5.u. 00] appears.</p>
<p>2 Setting the unit to a pound</p> 	<p>Press the Zero/Tare key several times to specify [8 3.5.u. 16].</p>

Example: To change the default factory settings to pound units use [835.u.] in the factory settings. (cont.)

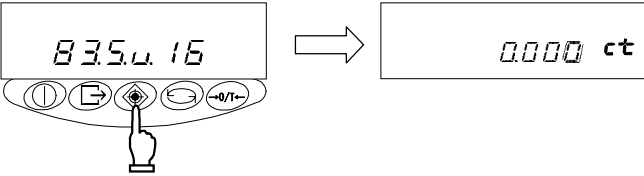
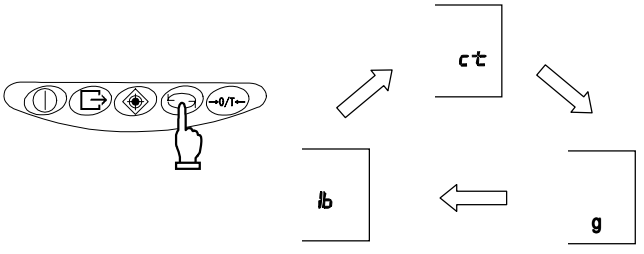
<p>3 Pressing the [Set] key to restore measurement mode.</p> 	<p>Pressing the Set key will reset the measurement mode</p>
<p>4 Pressing the [Function] key to change the units of measurement</p> 	<p>Press the Function key. Each press of the key changes the units of measurement to be displayed, as follows: [ct] → [g] → [lb] → [ct] → . . .</p>

Key Points of the Procedure

1. When set values are entered in the function items [815.u.] to [855.u.] prior to use, the desired unit of measurement to be displayed can be selected simply pressing the **Function** key. For more information on the units of measurement that can be set, please refer to “4.2 Description of Functions,” on page 13.
2. The units are displayed in the same sequence as the settings made from [815.u.] to [855.u.].
3. If [00] is set, no unit of measurement will be displayed, even when units of measurement are set in subsequent items.
4. [00] cannot be set in [815.u.].
5. If the same unit of measurement is set multiple times, the second time (and all subsequent times) the unit(s) occurs, it will be ignored when the display switches.

6. Calibrating the Balance

Since electronic balances are affected by gravity gravitational acceleration, they produce different values in various locations. Therefore, before use, balances must be calibrated at the location where they are installed. Calibration is also required after long periods without use, or if a balance begins to produce inaccurate values.

Calibration of a balance, or “span adjustment,” is required to produce accurate measurements.

Always perform calibrations without samples loaded on the measurement pan.

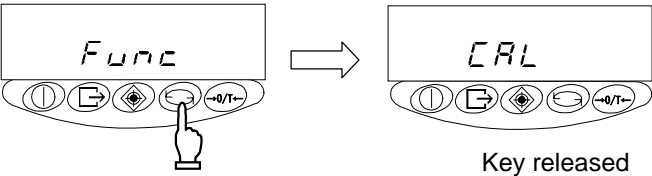
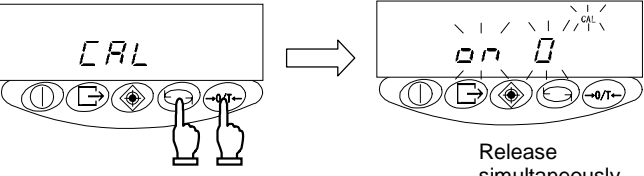
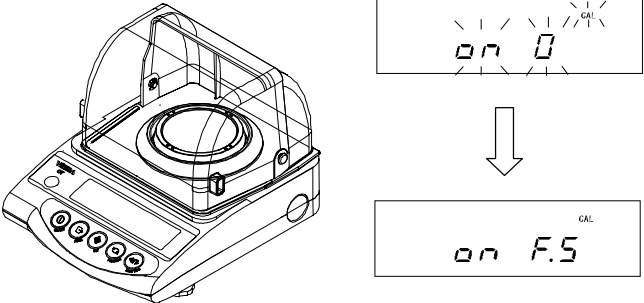
<p>1 Activating the span adjustment function</p>  <p>Pressed continuously</p> <p>Key released</p>	<p>Press and hold down the Function key.</p> <p>Release the key when the display changes from [Func] to [CAL].</p>
<p>2 Starting the span adjustment</p>  <p>Release simultaneously.</p> <p>Press the Function key while holding down the Zero/Tare key.</p>	<p>Press the Function key while holding down the Zero/Tare key, then release both keys simultaneously. The display flashes [0n 0], indicating that zero-point calibration is underway.</p>
<p>3 Zero calibration</p> 	<p>Zero-point calibration is finished when the display changes to [0n F.5]. Proceed to the calibration of the capacity point.</p>

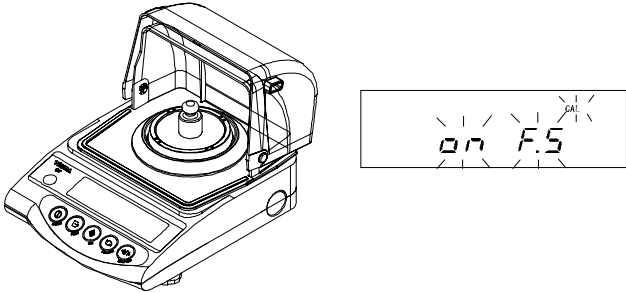
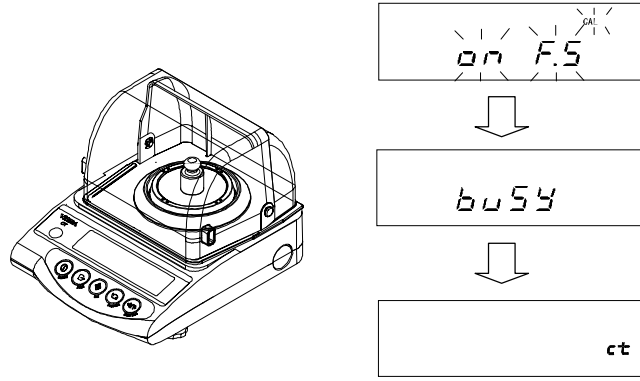
<p>4 Calibrating the capacity point</p> 	<p>Open the windshield. Load the calibration weight in the center of the balance. Close the windshield. The display flashes, indicating that capacity point calibration is in progress.</p>
<p>5 Terminating the span adjustment</p> 	<p>When the calibration of the capacity point is finished, the original measurement mode is restored.</p>

Key Points of the Procedure

- Pressing the **Function** key in Step 2 interrupts the span adjustment and returns you to the original measurement mode.
- The calibration weight used for span adjustment should be heavier than half the capacity of the balance.
To implement a calibration as precisely as possible, use a weight close to the capacity of the balance.
Calibration weights can be ordered from Shinko. For ordering information, please contact Shinko.
- If problems arise during span adjustments, one or more of the following error messages will appear:
 - [O - E r r]: The calibration weight exceeds the capacity of the balance.
 - [L - E r r]: The calibration weight is less than 50% of the capacity of the balance.
 - [Z - E r r]: The difference between before and after calibration values is too large (1.0% or more).
- The windshield should be opened and closed politely.

If error messages are displayed, calibration cannot take place. Check the weight and re-calibrate. If the same error continues after repeated calibrations using the correct weight, please contact our Marketing Division or Technical Service Division.

7. Input/output functions

7.1 Terminal Numbers and Functions

Terminal Number	Signal	Input/output	Function & remarks
1	EXT.TARE	Input	External tare subtraction
2	DTR	Output	HIGH (when balance is powered-up)
3	RXD	Input	Receiving data
4	TXD	Output	Transmitting data
5	GND	—	Signal ground

Compatible plug: TCP 0556-01-0201 (Hoshiden - supplied with balance)

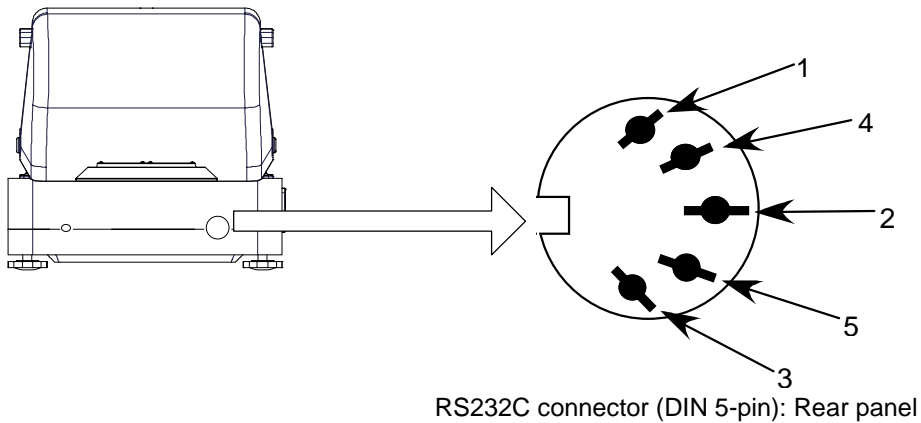

Tare subtraction (zero adjustment) is possible by connecting an external tare subtraction input and a signal ground, through contacts or a transistor switch. When following this procedure, secure a connection time of at least 400 milliseconds. (When the switch is off, the voltage maximum is 15 V; when the switch is on, the sink current is 20 mA or less.)

Caution:

Before plugging in the connectors, unplug the AC adaptor.

7.2 Connection between Balances and Personal Computers

■■■ Sample connection with an IBM-PC/AT compatible ■■■

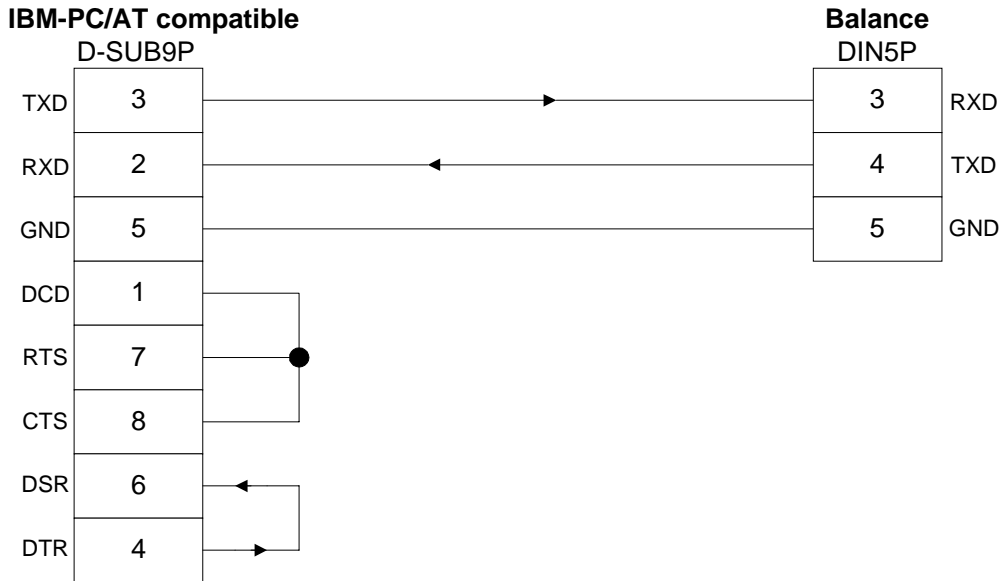

■■■ Sample connection with PC9801 ■■■

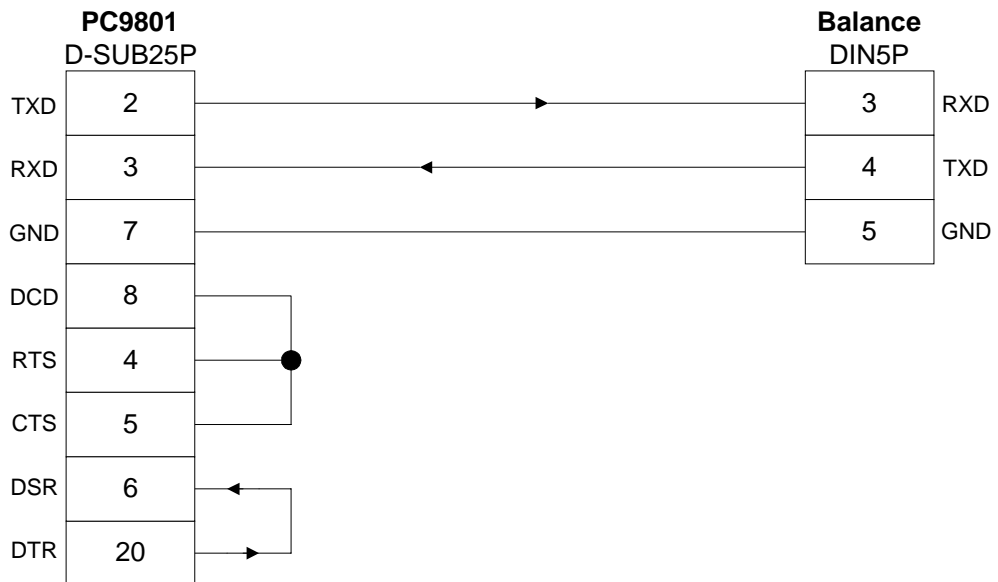

7.3 Interface Specifications

- (1) Transmission system Serial transmission with start-stop synchronization
- (2) Transmission rates 1200/2400/4800/9600 bps.
- (3) Transmission codes ASCII codes (8-bit)
- (4) Signal levels Compliant with EIA RS-232C
HIGH level (Data logic 0) +5 to +15 V
LOW level (Data logic 1) -5 to -15 V
- (5) One-character bit configuration Start bit: 1 bit
Data bit: 8 bits
Parity bit: 0/1 bits
Stop bit: 2 bits
- (6) Parity bit: none/odd/even

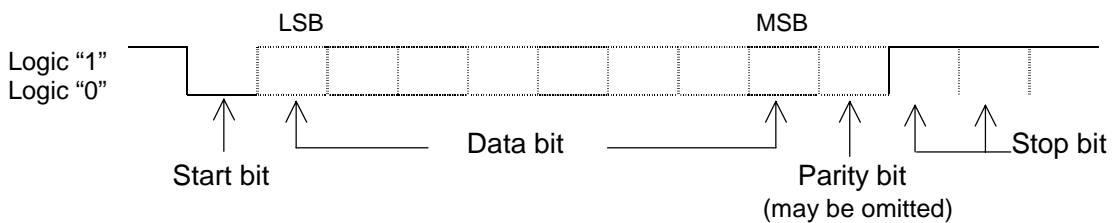

7.4 Output Data

By changing the function settings on the main unit of the balance, users can select either of the following formats: (See "4.2 Description of Functions," on page 13.)

7.4.1 Data Format

- (1) Six-digit numeric format
Composed of 14 characters, including the terminators (CR = 0DH, LF = 0AH).

1	2	3	4	5	6	7	8	9	10	11	12	13	14
P1	D1	D2	D3	D4	D5	D6	D7	U1	U2	S1	S2	CR	LF

- (2) Seven-digit numeric format
Composed of 15 characters, including the terminators (CR = 0DH, LF = 0AH). A parity bit can also be appended.

1	2	3	4	5	6	7	8	9	10	11	12	13	14	15
P1	D1	D2	D3	D4	D5	D6	D7	D8	U1	U2	S1	S2	CR	LF

- (3) Six-digit numeric format for model provided with an auxiliary scale interval
Composed of 15 characters, including the terminators (CR=0DH, LF=0AH), with "/" added to the left of the auxiliary-scale-interval place.

1	2	3	4	5	6	7	8	9	10	11	12	13	14	15
P1	D1	D2	D3	D4	D5	D6	D7	D8	U1	U2	S1	S2	CR	LF

- (4) Seven-digit numeric format for model provided with an auxiliary scale interval
 Composed of 16 characters, including the terminators (CR=0DH, LF=0AH), with “/” added to the left of the auxiliary-scale-interval place.

1	2	3	4	5	6	7	8	9	10	11	12	13	14	15	16
P1	D1	D2	D3	D4	D5	D6	D7	D8	D9	U1	U2	S1	S2	CR	LF

7.4.2 Polarities (P1: one character)

P1	Code	Description
+	2BH	When data is zero or positive
-	2DH	When data is negative
(SP)	20H	When data is zero or positive

7.4.3 Numeric data

Six-digit numeric format: (D1–D7: seven characters)

Seven-digit numeric format: (D1–D8: eight characters)

D1–D7 (D8)	Code	Description
0–9	30H–39H	Numerical value 0–9
.	2EH	Decimal point (floating position) When the data is an integer, it may be omitted and replaced with a blank space (SP) in the lowest-order place.
(SP)	20H	Space: zero of leading portion of value (leading zero suppress)
/	2FH	Delimiter to be inserted to the left of the auxiliary-scale-interval place

7.4.4 Units (U1, U2: two characters)

All the codes are ASCII codes.

U1	U2	Code	Meaning	Balance indicators	
C	T	43H	54H	carat	ct
(SP)	G	20H	47H	gram	g
O	Z	4FH	5AH	ounce	oz
L	B	4CH	42H	pound	lb
O	T	4FH	54H	troy ounce	oz t
D	W	44H	57H	pennyweight	dwt
G	R	47H	52H	grain	▶ (lower right)
T	L	54H	4CH	tael (Hong Kong)	ti
T	L	54H	4CH	tael (Singapore, Malaysia)	ti ▶ (upper right)
T	L	54H	4CH	tael (Taiwan)	ti ▶ (lower right)
M	O	4DH	4FH	momme	mom
t	o	74H	6FH	tola	to

7.4.5 Status 1 (S1: one character)

S1	Code	Description
(SP)	20H	Space

7.4.6 Status 2 (S2: one character)

S2	Code	Description
S	53H	Data stable
U	55H	Data unstable
E	45H	Data error (data other than S2 is invalid.) [0 - E r r], [u - E r r]
(SP)	20H	No status specified

7.5 Input Commands

Users can control the balance remotely by transmitting commands from an external device. Two types of control commands are available:

- (1) Instruction for tare subtraction
- (2) Setup of output control

7.5.1 Command Transmission Method

- (1) A command is transmitted to the balance from an external device. Since the data flow (transmission and reception) is stored by a full-duplex system, commands can be transmitted regardless of their data-transmission timing.
- (2) When the balance has executed the received command, it activates a normal end response or transmits the requested data, via the transmitting command. If the balance was unable to execute the command or received an erroneous command, it transmits an error end response. If the balance is working properly, it usually returns a response within a second after it receives the transmitted command. If the balance receives a transmission while it is conducting a procedure (such as the setup of a function or a span adjustment), it will transmit a response when the procedure finishes.
- (3) When transmitting more than one command to the balance from a remote device, wait until you have received a confirmation on the first transmission before transmitting the next.

7.5.2 Command format

- (1) Command format
Composed of four characters (ASCII), including the terminators (CR=0DH, LF = 0AH)

1	2	3	4
C1	C2	CR	LF

- (2) Instruction for tare subtraction (zero adjustment)

C1	C2	Code	Description	Value	Response
T	(SP)	54H	20H	Instruction for tare subtraction (zero adjustment)	None A00: Normal end E01: Tare subtraction cannot be executed due to an error in the weight value.

(3) Setup of output control

C1	C2	Code		Description
O	0	4FH	30H	Stop output
O	1	4FH	31H	Output continuous at all times
O	2	4FH	32H	Output continuous if stable (stop output if unstable)
O	3	4FH	33H	Outputs once by pressing <input type="button" value="Print"/> key (irrespective of whether stable).
O	4	4FH	34H	Outputs once if stable. Outputs if the balance is stable when a sample is loaded after the preceding sample has been removed and the balance indicated zero, or less.
O	5	4FH	35H	Outputs once if stable, and stops output when unstable. Even if the sample is not replaced, the balance is output once when it stabilizes next time (including the zero indication).
O	6	4FH	36H	Outputs once if stable, and outputs continuously when unstable. Even if the sample is not replaced, output of the balance stops when it stabilizes after being output once.
O	7	4FH	37H	Pressing <input type="button" value="Print"/> key causes the balance to output once when stable.
O	8	4FH	38H	Output once immediately.
O	9	4FH	39H	Output once after stabilization.

The output controls executed with commands [O0] - [O7] work the same as the output controls executed through function setup on the main unit of the balance.

The commands [O8] and [O9] are data request commands issued to the balance.

Once any command from [O0] to [O9] is executed, the balance runs that function until another command is entered. However, if the balance is switched off and on again, the output control is reset to the initial function (function set value).

7.5.3 Response Output

(1) Response output format

Composed of five characters, including the terminators (CR = 0DH; LF = 0AH)

1	2	3	4	5
A1	A2	A3	CR	LF

(2) Types of response outputs

A1	A2	A3	Code			Description
A	0	0	41H	30H	30H	Normal end
E	0	1	45H	30H	31H	Command error (Abnormal command received; other errors)



8. Operating the Balance with the Battery (CT-600CE)

This function can be used only when the balance is battery-operated.

8.1 Specifications



- Built-in nickel-cadmium battery
- Charging time: Approximately 12 hours
- Drive time: Approximately 32 continuous hours
- Number of charge/discharge cycles: 300 or more

8.2 Charging Method

While the balance is battery-operated, [] stays on. The indicator flashes [] (charging required) when battery capacity decreases. If the balance flashes [], charge the battery by following these steps:

- (1) Connect the dedicated AC adaptor to the balance.
- (2) Turn the balance off.
- (3) Charging takes approximately 12 hours, with power switched off. Charging the battery longer than 12 hours decreases battery life.

8.3 User Precautions

1. Once charging is complete, use the balance without the AC adaptor to avoid over-charging. This can occur since the balance continues to charge the battery with a weak current when the power is switched on. Overcharging will also decrease battery life.
2. When the balance is used for the first time after purchase, the operating time may be shorter than when using a fully charged battery. This is due to natural discharge of the battery. Although the balance can be used while [] is flashing, it should be recharged as soon as possible.
3. When the battery displays no indication, or an indication disappears quickly after the balance is switched on, battery capacity is low. In these cases, either charge the battery immediately or plug in the AC adaptor.
4. Charging the battery while [] is displayed reduces battery life.
5. Operable hour will be shorten when [$n \quad LF \quad 1 / 2$] is selected, because some power is consumed for interface even with no output.



Cautions

To operate the balance safely, observe the following (failure to do so could result in malfunctions, breakage, burst batteries, or fire):

1. Do not disassemble or modify the battery. Do not reverse the balance connection or short-circuit the positive and negative polarities of the balance.
2. Use only the supplied AC adaptor.
3. Do not incinerate used batteries. Dispose as hazardous material only.





9. Operating the Balance with the Dry Cell Battery (CT-600DBCE)

This function can be used only when the balance is dry-cell-battery-operated.

9.1 Specifications

- Cell type for use: 9 Volt (alkali type recommended)
- Drive time: Approximately 20 continuous hours
depend on model, storage and operation condition

9.2 User Precautions

1. While the balance is battery-operated, [] stays on. The indicator flashes [] when battery capacity decreases. If the balance flashes [], change the battery at an early stage.
2. The balance can be operated with AC adaptor, while the dry cell battery is installed. ([] does not show in this case.)
3. Operable hour will be shorten when [n / F / 2] is selected, because some power is consumed for interface even with no output.



Cautions To operate the balance safely, observe the following (failure to do so could result in malfunctions, breakage, burst batteries, or fire):

1. Do not disassemble or modify the battery. Do not reverse the balance connection or short-circuit the positive and negative polarities of the balance.
2. Use only the supplied AC adaptor.
3. Do not put batteries into fire.

10. Removing the Windshield

When you remove the windshield, follow the instruction in sequence.

11. Troubleshooting

The numbers in () indicate reference pages

Symptom	Cause	Possible remediation
There is no indication on the display.	The AC adaptor is not connected.	→ Check that the AC adaptor is connected (8).
The display is unstable. [M] remains flashing without changing.	The balance is subject to air currents or vibration. The balance is situated on an unstable surface. An object is contacting the sample being measured, the measuring pan, or the tare.	→ Check Precautions on Use (2–4).
Weight indication contains an error.	An error was made in the tare subtraction procedure. The adjusters remain lifted, resulting in an incorrect level. The indication values are inconsistent after long hours of use, or because the balance has been moved to a new location.	→ Review the tare subtraction. (10). → Check the level. (8). → Execute span adjustment on the balance. (17).
[O - Err] appears before the capacity is reached.	Gross weight exceeded the capacity of the balance (weight range = container + weight of sample). A section of the mechanism is damaged.	→ Check the total weight. → Execute tare subtraction again. → Contact our Technical Service Division or your local dealer.
[U - Err] is displayed.	A foreign object is caught between the measuring pan (pan base) and the balance. A section of the mechanism is damaged.	→ Remove the measurement pan and examine the surface beneath it.
[b - Err] is displayed. [d - Err] is displayed.	The balance is exposed to static electricity or noise. The electrical system of the balance is malfunctioning.	→ Contact our Technical Service Division or your local dealer.
During span adjustment: [O - Err] is displayed. [1 - Err] is displayed. [2 - Err] is displayed.	A weight heavier than the capacity was used. The reference weight is less than 50% of the capacity. Calibration produced an error of 1.0% or more.	→ Check that the span adjustment procedure was performed correctly. (17).
During battery installation: The indication disappears. [] flashes. No indication is produced.	The automatic power-off function was activated. (CT-600CE) The rechargeable battery capacity is low. (CT-600DBCE) The dry cell battery capacity is low.	→ Switch on the power again. Deactivate the Automatic power-off function, if necessary. (13). → (CT-600CE) Recharge the battery. (25). → (CT-600DBCE) Replace the dry cell battery. (8) → Operate the balance with the AC adaptor.

12. Specifications

12.1 Basic Specifications

Model	CT-600CE / CT-600DBCE			
Unit of measurement displayed	Max	Min	e	d
Carat (ct)	600 (ct)	0.1 (ct)	0.01 (ct)	0.001 (ct)
Gram (g)	120 (g)	0.02 (g)	0.01 (g)	0.001 (g)
Weight measuring method	Tuning fork vibration method			
Size of measuring pan	φ80 mm			
Output	Compliant with RS232C			
Windshield	Provided			

12.2 Common Specifications

- (1) Tare subtraction range..... Total capacity
- (2) Liquid-crystal display (LCD)..... Seven segments (two segments in leading part) ,
Maximum digits indication: seven digits,
Segment height: 16.5 mm.
- (3) Measuring function Weight mode
- (4) Overload indication..... [O - E r r] is displayed if weight capacity + 9
intervals are exceeded.
- (5) Compatible printer CSP-160
- (6) Operating temperature and humidity ranges .. 10°C to 30°C, 80%RH or less
- (7) AC adaptor..... Dedicated AC adaptor: 230 V AC - 9 V DC

12.3 Capacity and readability by Unit

Unit of measurement displayed	CT-600CE / CT-600DBCE		
	Capacity	Verification scale interval	Auxiliary scale interval
ct (ct)	600	0.01	0.001
g	120	0.01	0.001
oz (oz)	4.2	0.0001	0.00001
lb (lb)	0.26	0.0001	0.00001
oz t (ozt)	3.8	0.0001	0.00001
dwt (dwt)	77	0.01	0.001
▶ (grain)	1800	0.1	0.01
ti (Hong Kong)	3.2	0.0001	0.00001
ti (Singapore, Malaysia)	3.1	0.0001	0.00001
ti (Taiwan)	3.2	0.0001	0.00001
mom	32	0.001	0.0001
to (to)	10	0.001	0.0001

13. Conversion Table of Units

unit	Gram	carat	ounce	pound	troy ounce	penny weight
1g	1	5	0.03527	0.00220	0.03215	0.64301
1ct	0.2	1	0.00705	0.00044	0.00643	0.12860
1oz	28.34952	141.74762	1	0.06250	0.91146	18.22917
1lb	453.59237	2267.96185	16	1	14.58333	291.66667
1ozt	31.10348	155.51738	1.09714	0.06857	1	20
1dwt	1.55517	7.77587	0.05486	0.00343	0.05	1
1GN	0.06480	0.32399	0.00229	0.00014	0.00208	0.04167
1tl (HK)	37.429	187.145	1.32027	0.08252	1.20337	24.06741
1tl (SGP,Mal)	37.79936	188.99682	1.33333	0.08333	1.21528	24.30556
1tl (Taiwan)	37.5	187.5	1.32277	0.08267	1.20565	24.11306
1mom	3.75	18.75	0.13228	0.00827	0.12057	2.41131
1to	11.66380	58.31902	0.41143	0.02571	0.37500	7.5

unit	grain	tael (Hong Kong)	tael (Singapore, Malaysia)	tael (Taiwan)	momme	tola
1g	15.43236	0.02672	0.02646	0.02667	0.26667	0.08574
1ct	3.08647	0.00534	0.00529	0.00533	0.05333	0.01715
1oz	437.5	0.75742	0.75	0.75599	7.55987	2.43056
1lb	7000	12.11874	12	12.09580	120.95797	38.88889
1ozt	480	0.83100	0.82286	0.82943	8.29426	2.66667
1dwt	24	0.04155	0.04114	0.04147	0.41471	0.13333
1GN	1	0.00173	0.00171	0.00173	0.01728	0.00556
1tl (HK)	577.61774	1	0.99020	0.99811	9.98107	3.20899
1tl (SGP,Mal)	583.33333	1.00990	1	1.00798	10.07983	3.24074
1tl (Taiwan)	578.71344	1.00190	0.99208	1	10	3.21507
1mom	57.87134	0.10019	0.09921	0.1	1	0.32151
1to	180	0.31162	0.30857	0.31103	3.11035	1