

Intrinsically Safe Explosion-Proof Electronic Scale

# GZH-(B)Ex Series

## Operation Manual

### Instructions

- To ensure safe and proper use of the balance, please read this manual carefully.
- After reading this manual, store it in a safe place near the balance, so you can review it as needed.

**VIBRA**

SHINKO DENSHI CO., LTD.

# CAUTION

Thank you for purchasing the **GZH Series** Intrinsically Safe Explosion-Proof ElectronicScale.

Use apparatus correctly according to Operation manual, otherwise it will cause dangerous for life and cause disaster like factory explosion by the gas ignition. In the case of improper use, no safety shall be guaranteed.

Before operation, the law and technical standard of the country where apparatus is operated shall be confirmed whether target gas suits the gas classification, otherwise it will be dangerous for life and cause disaster like factory explosion by the gas ignition.

Any modification of apparatus shall be strictly prohibited. In the case of modification of apparatus, no safety shall be guaranteed at all.

Power supply shall be provided through an over current protector. (16A)

Only connect SELV circuits which are DI/RI from hazardous live to the I/O interfaces of the equipment.

Install equipment so that the power supply cord can be pulled out without hindrance in event of emergency.

# IECEX CERTIFICATE

Certificate No.: IECEx KEM 08.0016

Type of Protection: ia

Marking: Ex ia II B T4

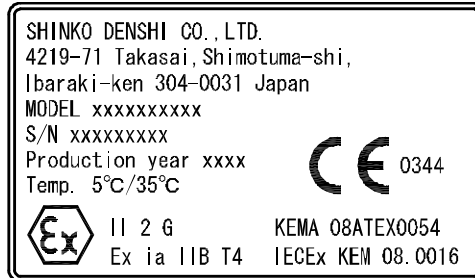

STANDARDS: IEC 60079-0:2004 Edition: 4.0

IEC 60079-11:2006 Edition: 5

Test Report: NL/KEM/ExTR08.0012/00

EQUIPMENT: Ta: +5°C to +35°C

POWER SUPPLY: GZH-B, EZ II-B and EZ-B Series:

1.5 V Manganese dry cell batteries National/Panasonic

Type R14P (NR). (6 non-rechargeable)

GZH, EZ II and EZ Series:

Maximum values  $U_i = 43$  V;  $I_i = 170$  mA;  $P_i = 0.931$  W;  $C_i = 7.1$  nF;  $L_i = 0.75$  mH.

The insulation between an intrinsically safe circuit and the frame of the (electrical) apparatus is not guaranteed. Avoid excess voltage.

# EC-TYPE EXAMINATION CERTIFICATE

Certificate No.: KEMA 08ATEX0054

Marking:

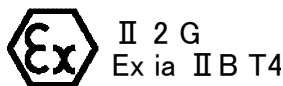

STANDARDS: EN 60079-0:2006

EN 60079-11:2007

Test Report: KEMA No. 211076300

EQUIPMENT: Ta: +5°C to +35°C

POWER SUPPLY: GZH-B, EZ II-B and EZ-B Series:

1.5 V Manganese dry cell batteries National/Panasonic

Type R14P (NR). (6 non-rechargeable)

GZH, EZ II and EZ Series:

Maximum values  $U_i = 43$  V;  $I_i = 170$  mA;  $P_i = 0.931$  W;  $C_i = 7.1$  nF;  $L_i = 0.75$  mH.

The insulation between an intrinsically safe circuit and the frame of the (electrical) apparatus is not guaranteed. Avoid excess voltage.

# Table of Contents

---

<b>CAUTION</b> .....	i
<b>IECEX CERTIFICATE</b> .....	ii
<b>Table of Contents</b> .....	iii

## **Conditions and Cautions for Installation**

---

1 Conditions of Installation (for the Explosion-Proof Type).....	1, 2
2 Cautions about Installing the Scale.....	3

## **Names and Functions of the Component Parts**

---

1 Outer View.....	4
2 Details of the Panel.....	5

## **Installation**

---

1 Checking Supplied Items.....	6
2 Cautions about Installation.....	7
3 Assembling the Small Scale.....	8
4 Horizontal Adjustment of the Scale.....	9
5 Installation of the Power Supply Box.....	10
6 How to Replace Batteries.....	11

## **Basic Operation of the Scale**

---

1 Getting Started and Checking Operation.....	12
2 Setting the ID Number (for Only the Power Supply Box Type).....	13
3 Taring and Weighing.....	14
4 Notes on Handling the Scale.....	15

## **Addition Function**

---

1 Select the Addition Function.....	16
2 Procedure for Making Addition and Displaying the Sum.....	17, 18

## **Limit Function**

---

1 Select the Limit function.....	19, 20
2 Setting by Weighing Actual Samples.....	21, 22
3 Setting by Entering Values.....	23, 24

## **Functions**

---

1 Functions and How They Work.....	25-28
2 Checking the Set Value.....	29
3 Change the setting.....	30

## **Calibration of the Scale**

---

1 Calibration with an Internal Weight.....	31, 32
2 Span Test with an Internal Weight.....	33, 34
3 Calibration with an External Weight.....	35, 36
4 Span Test with an External Weight.....	37, 38

## **Troubleshooting**

---

.....	39
-------	----

## **Standard Specifications**

---

1 Common Specifications.....	40
2 Configuration of Each Model.....	41

# Conditions and Cautions for Installation

## 1 Conditions of Installation (for the Explosion-Proof Type)

### ◆ Power supply box type

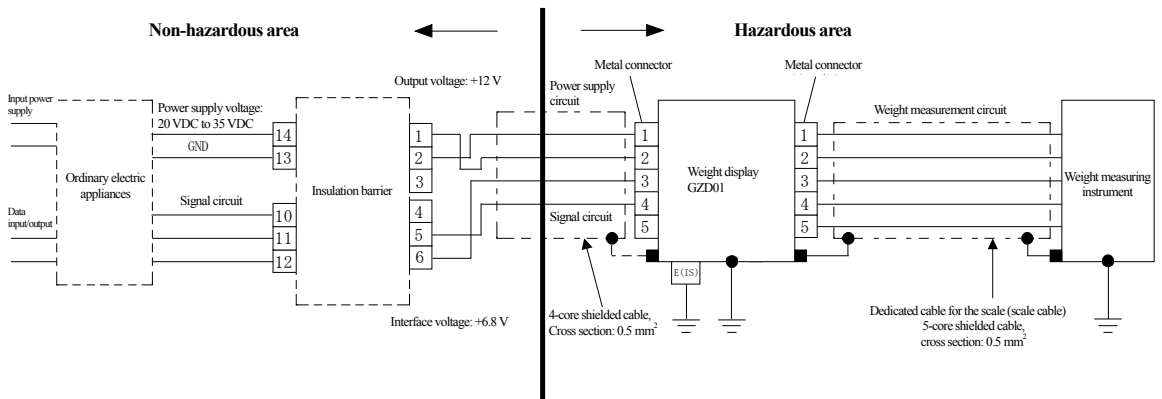

#### Input

- ◇  $P_i = 0.931$  [W]
- ◇  $U_i = 43$  [V]
- ◇  $I_i = 170$  [mA]
- ◇  $C_i = 7.1$  [nF]
- ◇  $L_i = 0.75$  [mH]
- ◇ Conditions for ordinary appliances connected to the insulation barrier:  
The voltage to ground of the input power supply and in the instrument shall not exceed 250 VAC, 50/60 Hz or 250 VDC during normal operation and even during a fault.
- ◇ The E(IS) shall be an intrinsically safe explosion-proof grounding pin for maintenance.

## ◆ Dry-cell battery type

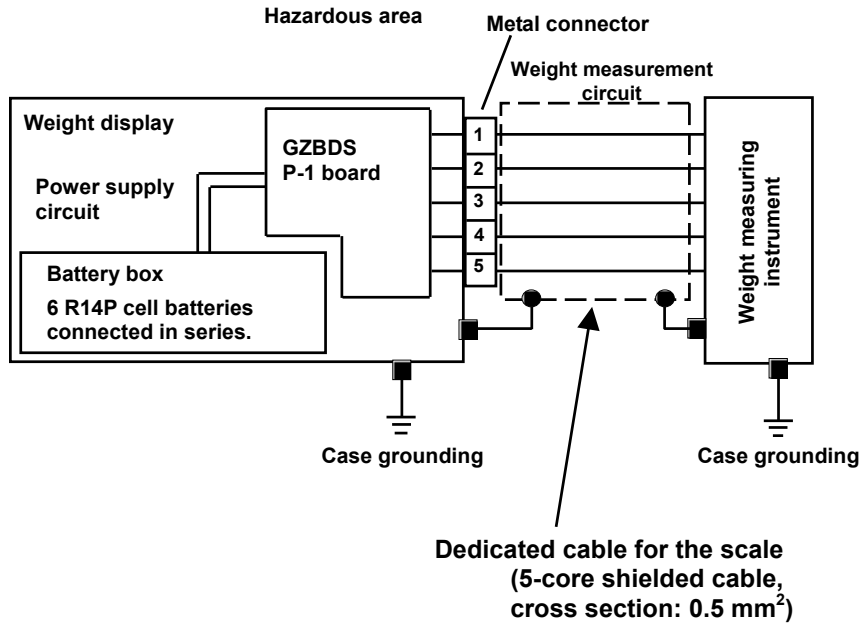

- ◇ Inductance of the dedicated cable for the scale (scale cable):  
0.01 mH or less
- ◇ Capacitance of the dedicated cable for the scale (scale cable):  
0.005  $\mu\text{F}$  or less
- ◇ Dry-cell batteries to be stored in the battery box:  
R14P from National/Panasonic (Connect 6 cells in series.)
- ◇ Battery replacement in a hazardous area is prohibited.

**2**

## **Cautions about Installing the Scale**

1. Be sure to replace dry cell batteries of the dry-cell battery type scale in a non-hazardous area.  
The type of the cell batteries is limited to C-size red manganese batteries (type: R14P from National / Panasonic).
2. The power cable of the power supply box type is laid between the hazardous area and the non-hazardous area.  
Be sure to have the specified gas flow prevention work performed for the lead-in section of the cable.
3. Never set the power supply box and the barrier in the hazardous area.
4. The standard power supply box is provided with a 5-m power cable.  
Options of extended cables are available in increments of 5 m to a maximum of 100 m. Use of our company's cables is recommended for the power supply box.
5. Establish a ground for the case when it is deteriorated by pressure.

# Names and Functions of the Component Parts

## 1 Outer View

### ◆GZH-(B)610Ex to (B)1500Ex

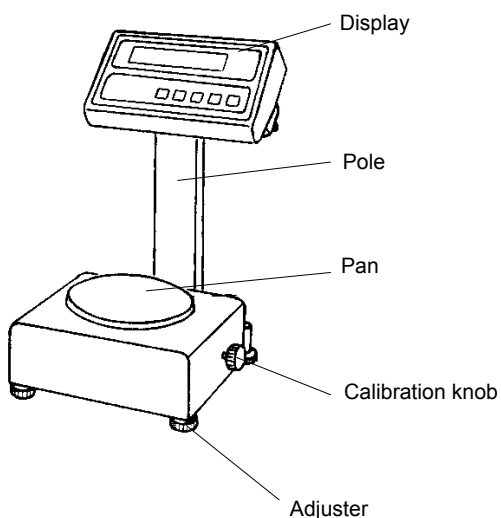

### ◆GZH-(B)3100Ex to (B)610Ex

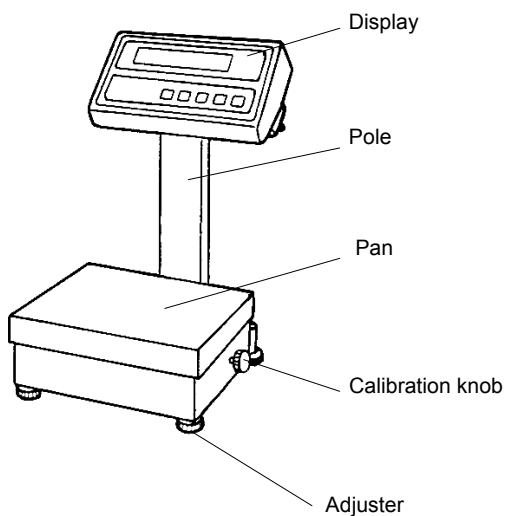

### ◆GZH-(B)30KEx

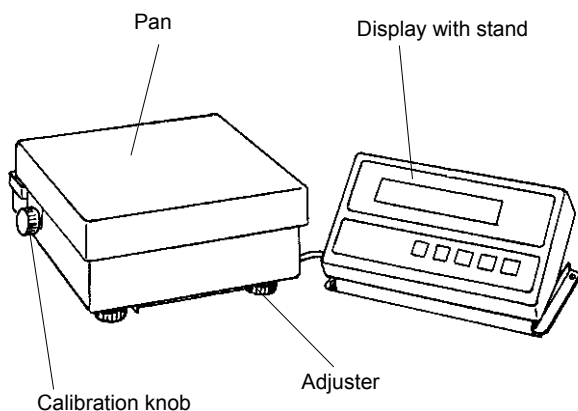

### ◆Power supply box

(Provided for the power supply box type only)

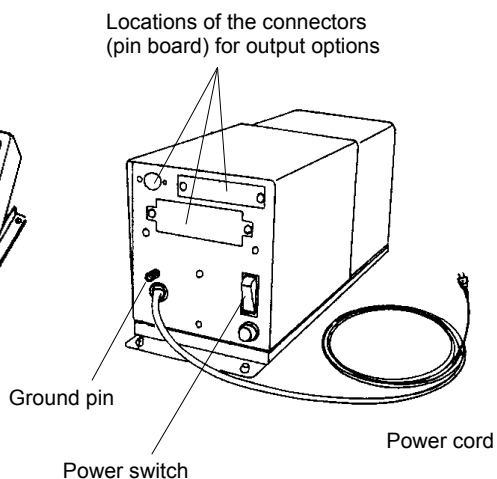



2

Details of the Panel

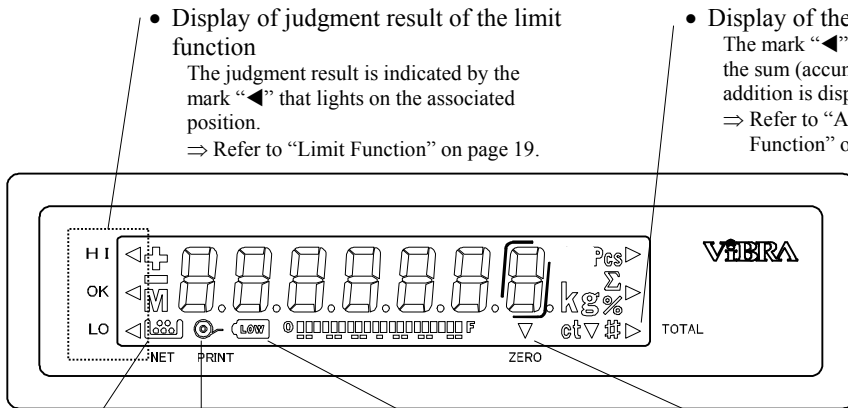

• **Display of judgment result of the limit function**  
 The judgment result is indicated by the mark “◀” that lights on the associated position.  
 ⇒ Refer to “Limit Function” on page 19.

• **Display of the sum**  
 The mark “◀” lights and the sum (accumulation) of addition is displayed.  
 ⇒ Refer to “Addition Function” on page 16.

• **Taring in progress**  
 This mark lights when the weight of the container (tare) is subtracted.  
 Taring and Weighing  
 ⇒ Refer to “Taring and Weighing” on page 14.

• **Print**  
 This mark lights when data is printed or output.  
 ⇒ Refer to “Functions” on page 25 and after.  
 (This mark stays out on the dry-cell battery type.)

• **Battery level**  
 This mark blinks when the battery capacity drops to the predetermined level.  
 ⇒ Refer to “How to Replace Batteries” on page 11 and after.  
 (This mark stays out on the power supply box type.)

• **Zero point**  
 This mark lights when the correct zero point is reached.  
 ⇒ Refer to “Taring and Weighing” on page 14.



Press this key to turn the scale on or off. ⇒ Refer to “Getting Started and Checking Operation” on page 12.  
 This key can be disabled on the power supply box type. ⇒ Refer to “Functions” on page 25 and after.



Press this key for output to the printer. Or use this key as an output command key for an installed output device.  
 ⇒ Refer to “Functions” on page 25 and after.



Limit key: Press this key to start the limit function. ⇒ Refer to “Limit Function” on page 19 and after.  
 Add key: Press this key for addition (accumulation) of data. ⇒ Refer to “Addition Function” on page 16.  
 This key works as an interrupt key during selection of a function or during setting of the limit function.



Set key: Press this key to set a limit value of the limit function or to move the digit for value entry when setting numerical values.  
 ⇒ Refer to “Limit Function” on page 19 and after.  
 Switch key: Press this key to display a sum (accumulation). ⇒ Refer to “Addition Function” on page 16.  
 Press this key to start or end the selection of a function. ⇒ Refer to “Functions” on page 25 and after.









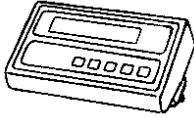
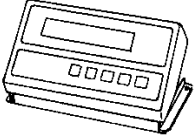
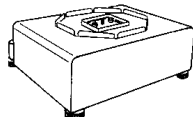

Zero/Taring key: Press this key to zero a readout. ⇒ Refer to “Taring and Weighing” on page 14.  
 The “Taring in progress” mark lights when you zero 1.5 % or more of the weighing capacity.

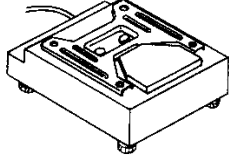
# Installation

## 1 Checking Supplied Items

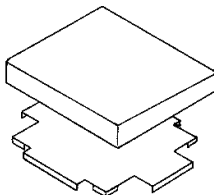
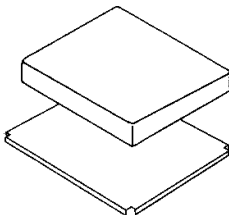
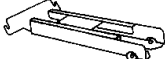
Check the supplied items of the model you purchased and the accessories of the power supply part shown in the following table. If any items are missing or broken, please contact immediately the retailer of the scale or our Sales Office.

Accessory	GZH-(B)610Ex to (B)1500Ex	GZH-(B)3100Ex tp (B)6100KEx	GZH-(B)30KEx
Display			 Display with stand
Scale (main body)			
Pan base			(Preinstalled in the main body)
Pan		 Pan guide	 Pan guide
Pole	 Pole	 Pole knob, Wing bolt ×2	This is optional, so it is not included in the standard specifications.

## ◆ Accessories of the Power Supply Unit

### ◆ Power supply box type

- (1) Power supply box ×1  
with spare fuses

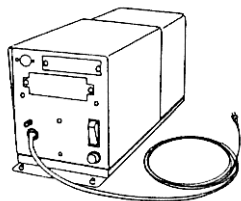

### ◆ Dry-cell battery type

- (1) C-size manganese dry-cell battery (R14P) ×6  
※R14P(NR):National / Panasonic

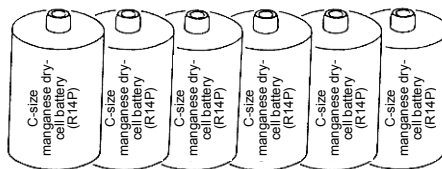

- (2) Power supply cable (5 m) ×1



- (2) Small wrench ×1  
(Subtense: 2 mm)



## 2 Cautions about Installation

Install the scale in the best environment available. Using the scale in any of the environments shown below may cause weighing errors or instrument failures:

- 1** A loose floor on which the scale sinks when loaded with a sample



- 2** An unstable base or a location subjected to vibration



- 3** A location close to an air-conditioner

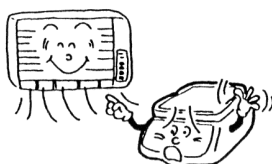

- 4** A location exposed to direct sunlight

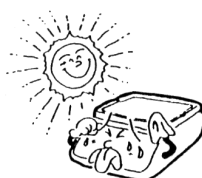

- 5** A location subjected to abrupt changes of ambient temperatures or humidity



### 3 Assembling the Small Scale

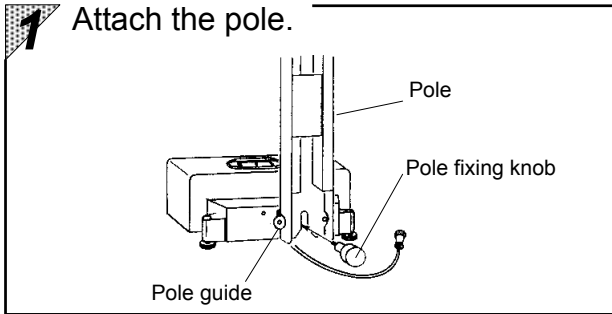

Install the accessory pole to the rear guide with the pole knob.

Unless the pole fits the guide correctly or the pole knob screw is not tightened enough, the display may tilt or flicker.

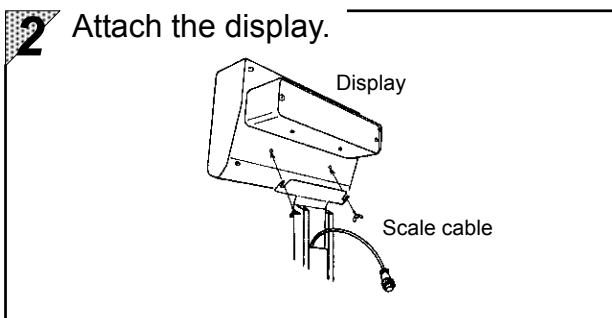

Pass the scale cable in the pole and attach the display to the pole.

Connect the scale cable and the power cable to the display.

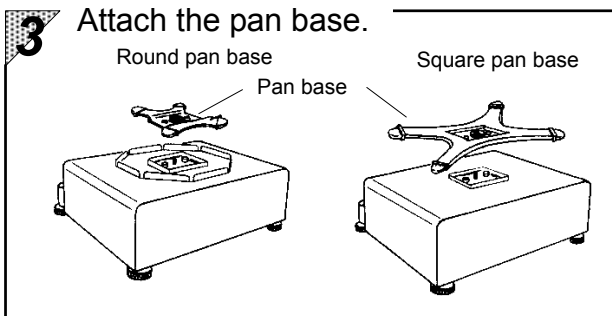

Set the pan base with its screw hole aligned to the projection on the main body and tighten the screw with a screwdriver or an appropriate coin.

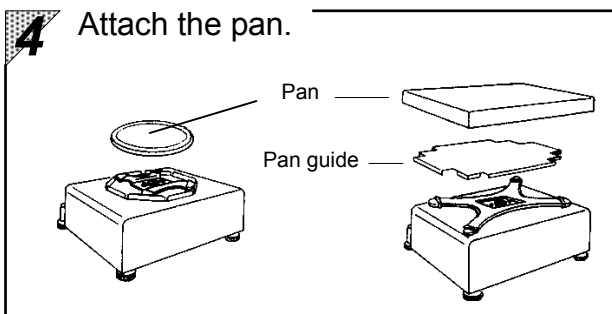

A pan guide is added under the square type pan.

\* Model GZH-(B) 30KCEX is a separate type that does not require pole installation. The pan base is preinstalled in the main body.

## 4 Horizontal Adjustment of the Scale

### ◆GZH-(B)610Ex to (B)6100Ex

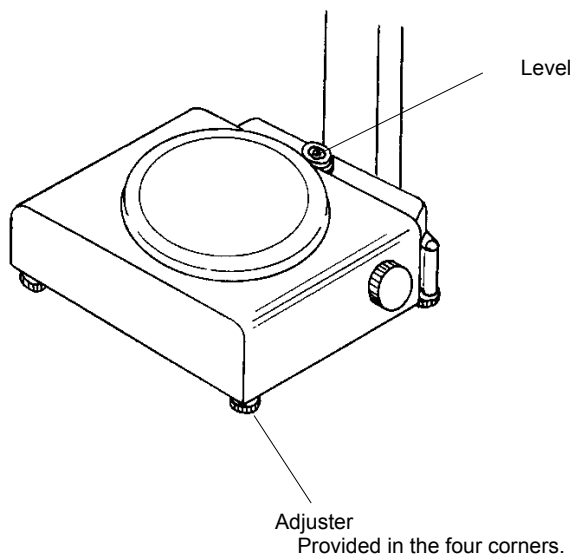

### ◆GZH-(B)30KEx

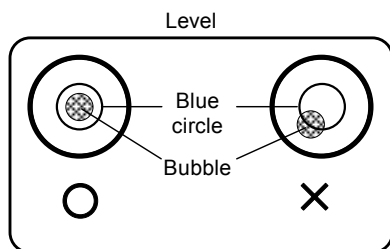
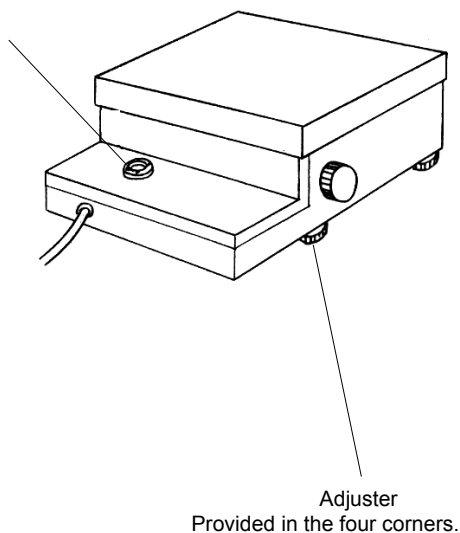

Rotate the four adjusters until the bubble in the level fits within the blue circle.

Press the four corners to check for rattling of each adjuster.

## 5 Installation of the Power Supply Box

This section applies to the scale of the power supply box type. Jump to the next section when you use a dry-cell battery type.

First finish the cable installation work. Be sure to have the specified gas flow prevention work performed for the lead-in section of the cable because the section is laid between the hazardous area and the non-hazardous area.

**Be sure to extract the power cord from the wall socket before installing the power supply box.**

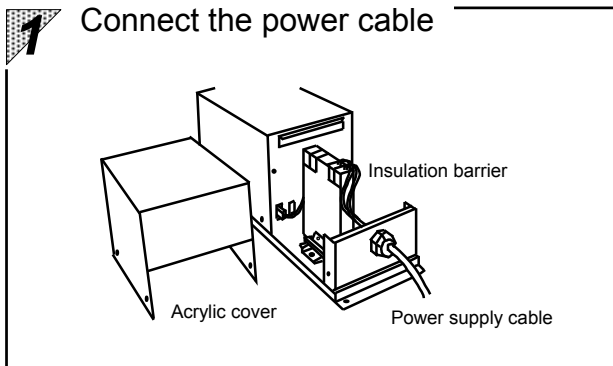

Remove the acrylic cover and connect the power cable.  
Connect the cable to the correct position referring to the following figure.

### Wiring diagram of the barrier

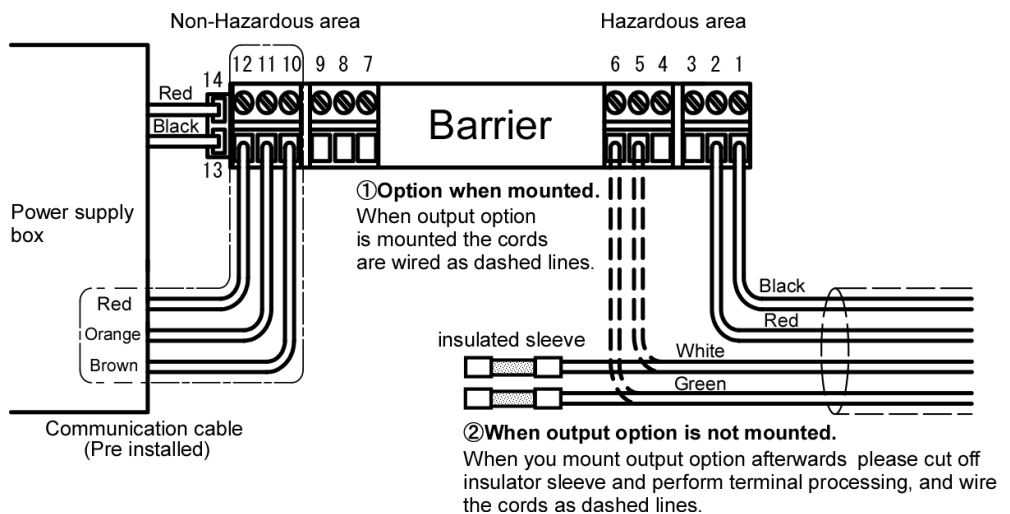

## 6 How to Replace Batteries

This section applies to the scale of the dry-cell battery type. Return to the previous section when you use a power supply box type. Be sure to replace batteries in a non-hazardous area.

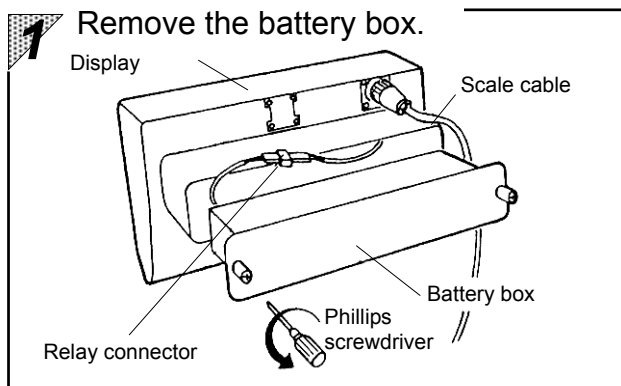

Loosen the screw in the rear of the display and the battery box can be removed.

Remove the relay connector in the battery box.

Do not pull the cable since it may cause wire breakage. Hold and pull the connectors when you disconnect the cables.

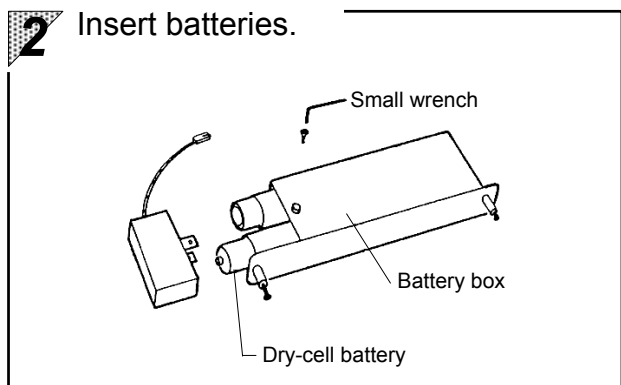

Remove the battery box cover with the small wrench in the accessory kit.

Replace the batteries in the correct direction.

Install the cover with the small wrench.

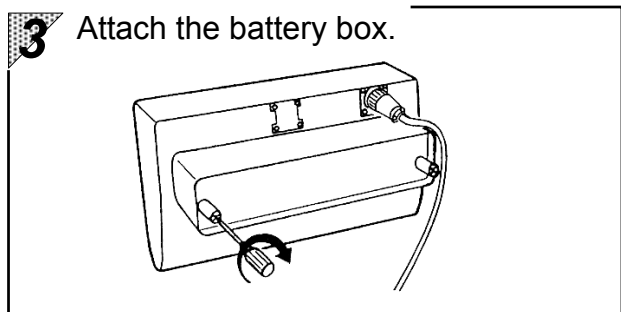

Connect the relay connector of the battery box and install it on the display.

### Important

The type of the cell batteries is limited to C-size red manganese batteries (type: R14P). Use of other batteries is strictly prohibited because they may not be of the required explosion-proof performance.

# Basic Operation of the Scale

## 1 Getting Started and Checking Operation

As for the power-supply box type, first turn on the power switch in the power supply box.

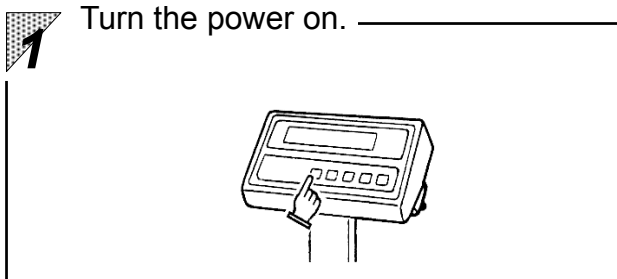

Press the  key on the panel, and all the indicators light up, showing that the instrument is operating.

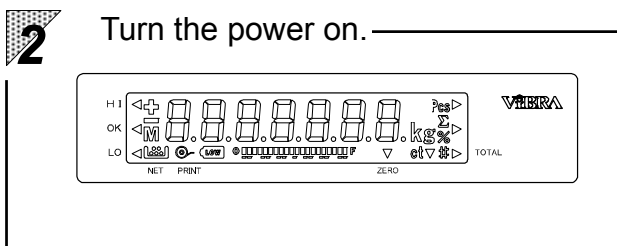

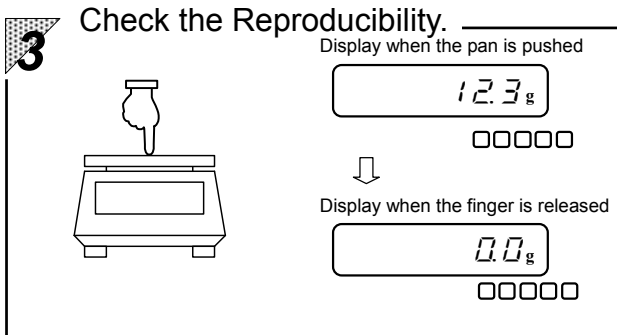

At this time, check that no LEDs nor LED segments stay out.

After a few seconds, zero is displayed in the weight display.

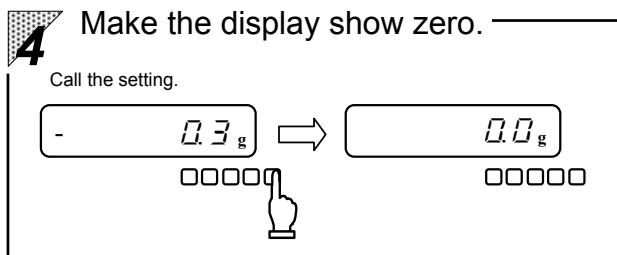

Push the pan slightly using your finger to check that the display readout changes. Also check that zero is indicated in the display after the finger is released.



If the display readout does not become zero, press the  key to make the display show zero. ⇒ Refer to “Set the zero point.”

\* For setting the zero point, set the scale to display zero when nothing is placed on the pan or approximately 1.5% of the weighing capacity is loaded.



## 2 Setting the ID Number (for Only the Power Supply Box Type)

You can use up to six digits in an ID number. The characters that you can use are “0” to “9,” “A” to “F,” “-,” and “\_” (blank).

**1** Call the ID number.

Call the setting.

Press and hold.

Release the finger.



The set value is displayed.

Press and hold the  key for a few seconds. Release the finger when the display changes from “F u n c ” to “C A L ” ⇒ “ i d ,” and the ID number is displayed.

**2** Enter the value to set.

Enter the ID number.

The set value is displayed.

Press the  key, and the leftmost digit blinks. Keep pressing the  key, and the value of the blinking digit changes. Select a value to set. (0 ⇒ 1 ⇒ 2 ⇒ 3 ···)

Press the  key, and the blinking shifts to the left to change the digit for value entry.

**3** Setting is over.

Setting is over.

Save the setting.

When the setting is over, press the  key, and the setting is saved and “PUSH 5.” is displayed.

Press the  key again, and the setting process is terminated and the weight display mode is resumed.

### 3 Taring and Weighing

**1** Taring operation

Place the tare (container) on the pan.

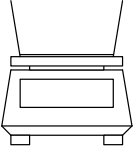



The weight of the tare (container) is displayed.

23.4 g

↓

Display after taring

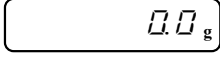
0.0 g

Place the tare (container) on the pan and press the  key, and the readout changes to zero. ⇒ Refer to “Taring.”



**2** Measure the net weight.

Place the sample in the container.

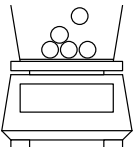

The net weight is measured.

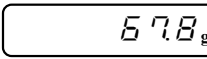
67.8 g



When samples are placed in the container, the net weight of the sample is displayed.

**3** Taring operation

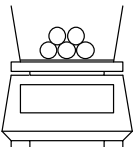

Display after taring

0.0 g

Press the  key, and the readout changes to zero. ⇒ Refer to “Taring.”



**4** Place additional samples.

Place additional samples in the container.

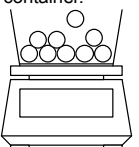

Result of weighing the added samples

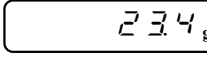
23.4 g

When additional samples are placed in the container, the weight of only the added samples is displayed.

#### Key points

1. When the zero point is accurately reached, the zero point is flagged with a “▼” mark. (This mark disappears when another value is displayed.)
2. If approximately 1.5% of the weighing capacity is displayed as zero, the mark that indicates that taring is ongoing (“”) is displayed. At this time, the weighable range is narrowed.

Weighable range = original weighing capacity – weight of the tare

## 4 Notes on Handling the Scale

The electronic scale is a precision instrument that requires careful handling. Using the scale in any of the environments shown below may cause weighing errors or instrument failures:

- 1** Load or unload samples on the scale carefully. Do not apply mechanical shocks to the instrument.
- 2** Do not permit any material to be inserted beneath the pan.



- 3** Do not leave a load over the weighing capacity on the scale (“Err” displayed). The weighing capacity = the weight of the tare + the weight of the sample
- 4** Calibration is recommended after installation or relocation or when the scale is used after being stored for an extended period of time. Refer to “Calibration of the Scale” on page 31 and after.

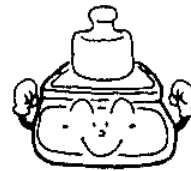

- 5** Be sure to replace batteries in the non-hazardous area. The type of the cell batteries is limited to C-size red manganese batteries (type: R14P).
- 6** Do not attempt to repair the scale because it may cause the explosion-proof performance to be lost and is very dangerous.
- 7** Do not attempt to modify the scale because it may cause the explosion-proof performance to be lost and is very dangerous.
- 8** Any faults or breakage cause by erroneous handling, repair, or modification by the user is not covered by the warranty.

# Addition Function

The addition function sums the results of weighing samples subdivided into several parts. This function is convenient when the total weight is checked at the time of filling, blending, or consecutive weighing small quantities.

## 1 Select the Addition Function

**1** Call the function.

Function Call

00 g

Press and hold.

Function Display

Func

Release the finger.

The first function is displayed.

1SEL. 0

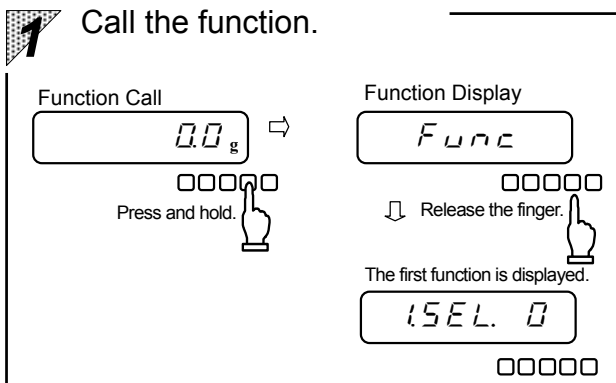

Press and hold the  key for approximately 4 seconds. When “Func” is displayed, release the finger. Now the function setting mode is assumed and the first item “1SEL. 0” (Function Selection) is displayed.  
⇒ For details, refer to pages 25 to 28.

**2** Select the Addition function.

Function Selection

1SEL. 0

Select the addition function.

1SEL. 1

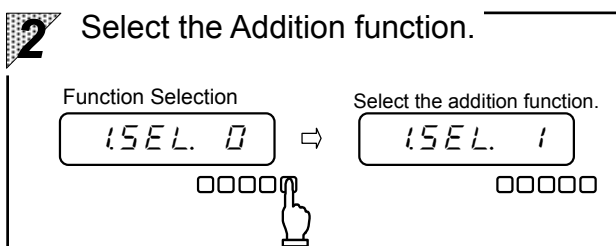

Press the  key, and the rightmost value changes. Then select the addition function “1.”

**3** Setting is over.

Setting is over.

1SEL. 1



Save the setting.

PUSH S.

Weight display mode is resumed.

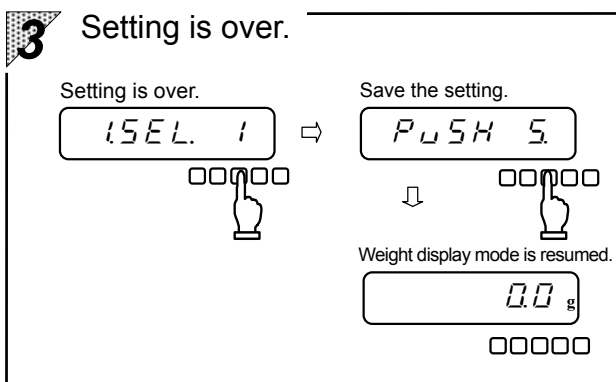
00 g



Press the  key, and the set value is saved and “PUSH S.” is displayed. Press the  key again, and the setting process is terminated and the weight display mode is resumed.

## 2 Procedure for Making Addition and Displaying the Sum

**1** Weigh the samples.

Place the sample in the container.

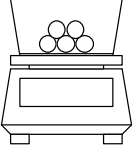

The net weight is measured.

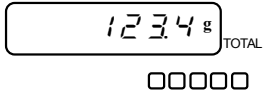

Place samples on the scale for weighing.

**2** Add the weight of the samples.

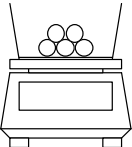

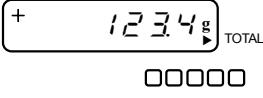

The result of the addition is displayed.

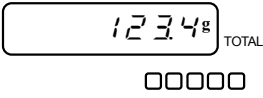

↓

The present weight is displayed.



Press the  key.

The sum is displayed together with the “▶” mark for temporary display of the addition result. After approximately 3 seconds, the original display is resumed.

**3** Set the zero point.

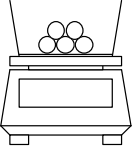

Display after the zero point was set.

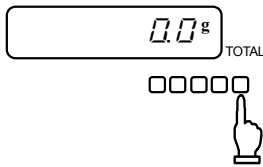

When additional samples are placed in the container, press the  key so that zero is shown in the display.

**4** Place additional samples.

Place additional samples in the container.

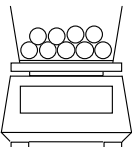

Result of weighing the added samples

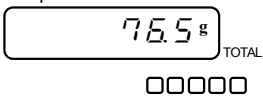

When additional samples are placed in the container, the weight of only the added samples is displayed.

**5** Add the weight of the samples.

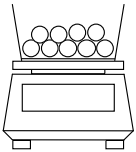

The result of the addition is displayed.

+ 199.9 g TOTAL

00000

↓

The present weight is displayed.

76.5 g TOTAL

00000

Press the  key.  
 The sum is displayed together with the “▶” mark for temporary display of the addition result. After approximately 3 seconds, the original display is resumed.

**6** Display the sum value.



The sum value is displayed.



+ 199.9 g TOTAL

00000

The present weight is displayed.

76.5 g TOTAL

00000

Press the  key.  
 The final sum is displayed together with the “▶” mark.  
 When the  key is pressed again, the original display is resumed.

**7** Clear the sum value.

The sum value is displayed.

+ 199.9 g TOTAL

00000



The sum value is displayed.

+ 0.0 g TOTAL

00000

While the sum is displayed, press the  key.  
 Zero is displayed, indicating that the sum is cleared.

**Key points**

1. The addition operation is enabled only when zero is displayed. If new samples are added after the present samples are unloaded, check beforehand that zero is displayed.
2. When the addition operation is over, press the  key to clear the sum value. This can prevent the sum by a new operation from being added to the preceding one if two or more addition operations are performed consecutively.
3. When “E - E r r” is displayed by pressing the  key, it indicates that you performed double addition, minus addition, or zero addition.

# Limit Function

The limit function allows the scale to store the upper and lower limit values for judgment of whether the measurement result falls within the limit values. This function is very convenient for identifying defective items or weighing predetermined quantities.

## ◆ Methods of Entering Limit Values

The following two methods are available and they can be used alone or in combination.

(1) Setting by weighing actual samples: Weigh the actual samples for the lower and upper limit values on the scale and save the weights.

(2) Setting by entering values: Use a key to enter the values of the lower and upper limits and save the values.

\* The entered limit values are stored in memory and are not erased by power-off.

\* The judgment result is indicated by HI, OK, or LO flagged with a “◀” mark on the panel.

HI: The measured value is greater than the upper limit value.....Upper limit value < measured value

OK: The measured value is within the limit values.....Upper limit value ≥ measured value ≥ lower limit value

LO: The measured value is smaller than the lower limit value.....Lower limit value > measured value

## 1 Select the Limit function

**1** Call the function.

Press and hold the  key for approximately 4 seconds. When “Func” is displayed, release the finger.

Now the function setting mode is assumed and the first item “1SEL. 0” (Function Selection) is displayed.

(⇒ For details, refer to pages 25 to 28.)

**2** Select the Limit function.

Press the  key, and the rightmost value changes. Then select the limit function “2.”

**3** Select a condition.

Function Selection

Select a condition.

Display: Condition  
 1 L.C.a. 1: Always judge.  
 1 L.C.a. 2: Judge only when the scale is stable.

Press the key, and the next item (condition) is displayed.

Press the key, and the rightmost value changes. Then select the value that you want to set.

**4** Select a range to cover.

Function Selection

Select a range to cover.

Display: Range to cover  
 12.L. 0: Detect when the limit is exceeded by 5 divisions or less.  
 12.L. 1: Detect when the limit is exceeded by 50 divisions or less.  
 12.L. 2: Detect both when the limit is exceeded and when it is not reached.

Press the key, and the next item (range to cover) is displayed.

Press the key, and the rightmost value changes. Then select the value that you want to set.

**5** Select a setting type.

Function Selection

Select a judgment type.

Display: Setting type  
 13.P.n. 1: Set both upper and lower limits.  
 13.P.n. 2: Set only the lower limit.  
 13.P.n. 3: Set only the upper limit.

Press the key, and the next item (setting type) is displayed.

Press the key, and the rightmost value changes. Then select the value that you want to set.

**6** Setting is over.

Setting is over.

Save the setting.

Weight display mode is resumed.

Press the key, and the setting is saved and “PUSH 5.” is displayed.



Press the key again, and the setting process is terminated and the weight display mode is resumed.



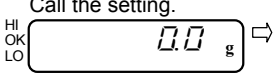

## 2 Setting by Weighing Actual Samples

If zero is not shown in the display, press the  key to make the display show zero before starting the procedure. If a container is used, perform the taring process to make the display show zero.

**1** Start setting the limit values.

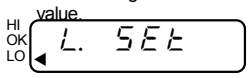
Call the setting.  

Start entering the lower limit value.  

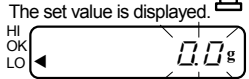
The set value is displayed. 

Press and hold the  key for approximately 3 seconds. When “L. SET” is displayed, release the finger. Now the lower limit value can be set.

The judgment display “LO” is flagged with the “◀” mark and blinks.

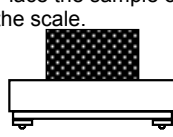

**2** Set the lower limit value.

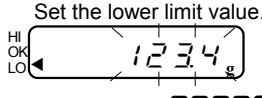
Place the sample on the scale. 

Set the lower limit value. 

Place the sample for the lower limit value on the scale and press the  key. The display disappears temporarily. When the lower limit value is saved, the display blinks.

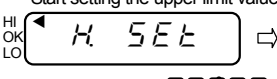
**3** Start setting the upper limit value.

Start setting the upper limit value.  

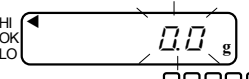
The set value is displayed. 

Press the  key, and the upper limit value can be set.

“H. SET” is displayed temporarily and the judgment display “HI” is now flagged with the “◀” mark.

**4** Set the upper limit value.

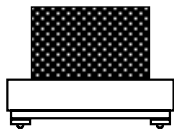
Place the sample on the scale. 

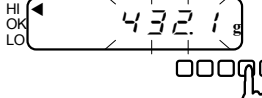
Set the upper limit value. 

Place the sample for the upper limit value on the scale and press the  key. The display disappears temporarily. When the upper limit value is saved, the display blinks.

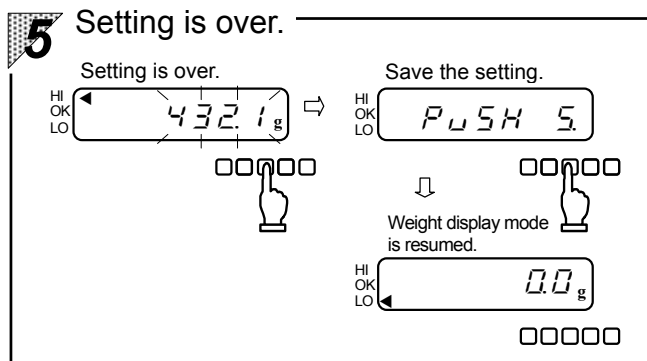



Press the **Set** key, and the setting is saved and "PUSH S." is displayed. Press the **Set** key again, and the setting process is terminated and the weight display mode is resumed.



**Key points**

- The operation procedure differs as follows depending on which judgment type is selected:  
 When "Set only the lower limit" is selected ⇒ Skip steps 3 and 4 and end with step 5.  
 When "Set only the upper limit" is selected ⇒ "H. SET" is displayed in step 1 and therefore you need not perform step 2.
- If a limit value has already been entered, the set value is displayed after "L. SET" or "H. SET." If a new limit is set, the value changes.
- If a negative value is set as a limit, the range to cover is set as "Detect both when the limit is exceeded and when it is not reached" including the minus value. If no limits are set, judgment is not performed.  
 ⇒ Refer to "Functions and How They Work" on pages 25 to 28.
- If all of the judgment displays "HI," "OK," and "LO" are flagged with the "◀" mark, the lower limit value is greater than the upper limit value. Try the procedure again.
- You can switch the process of "setting by weighing actual samples" to "setting by entering values" at some midpoint in the process.  
 The process of "setting by entering values" is enabled if you shift to step 2 of the process after setting limit values by weighing actual samples. This method is convenient when you change a value set by the process of "setting by weighing actual samples."
- You can switch the process of "setting by entering values" to "setting by weighing actual samples" at some midpoint in the process.  
 The process of "setting by weighing actual samples" is enabled if you place a sample on the scale and press the **Function** key after setting limits by entering values.

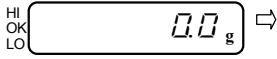
### 3 Setting by Entering Values

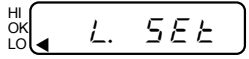
**1** Start setting the limit values.

Call the setting.   Start entering the lower limit value. 



Press and hold.  Release the finger. 

The set value is displayed. 

Press and hold the  key for approximately 3 seconds. When “L. SET” is displayed, release the finger. Now the lower limit value can be set.

The judgment display “LO” is flagged with the “◀” mark and blinks.

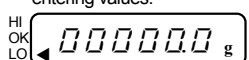

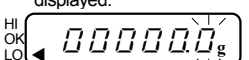
**2** Start the process of “setting by entering values.”

Start the process of “setting by entering values.”   The digit for value entry is displayed. 

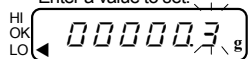

Press the  key, and the process of “setting by entering values” is enabled with all digits displayed. Only the LSD blinks, indicating that it is the digit for value entry.

**3** Enter a value to set.



Enter a value to set.  

The value changes each time the  key is pressed.

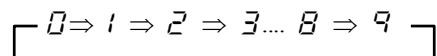
Select a value to set.



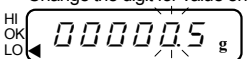



**4** Change the digit for value entry.

Change the digit for value entry.  

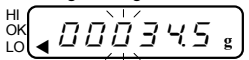

Press the  key, and the digit for value entry changes.

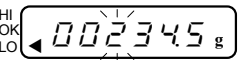
The MSD is used to set the plus or minus sign (+ or -).

**5** Enter the lower limit value.

Change the digit for value entry.   Enter a value to set.  

Repeat the steps 3 and 4.

Select the digit for value entry with the  key and select a value to set with the  key for entry of the lower limit value.

**6** Setting of the lower limit value is over.

Setting of the lower limit value is over. The display stays out while the value is being saved.

The set value is displayed.

The diagram shows a sequence of two states. In the first state, the display shows 'M' and is flanked by 'HI' and 'LO' indicators. Below the display are five small squares representing buttons, with a hand icon pointing to the second square from the left. An arrow points to the second state, where the display shows '234.5 g' and is flanked by 'HI' and 'LO' indicators. Below the display are five small squares representing buttons.

When the entering of the lower limit value is over, press the key. The display disappears temporarily. When the lower limit value is saved, the display blinks.

**7** Start setting the upper limit value.

Start setting the upper limit value. The display stays out while the value is being saved.

The set value is displayed.

The diagram shows a sequence of two states. In the first state, the display shows 'H. SET' and is flanked by 'HI' and 'LO' indicators. Below the display are five small squares representing buttons, with a hand icon pointing to the second square from the left. An arrow points to the second state, where the display shows '0.0 g' and is flanked by 'HI' and 'LO' indicators. Below the display are five small squares representing buttons.

Press the key, and the upper limit value can be set. "H. SET" is displayed temporarily and the judgment display "HI" is now flagged with the "◀" mark.

**8** Start the process of "setting by entering values."

Start the process of "setting by entering values." The digit for value entry is displayed.

The diagram shows a sequence of two states. In the first state, the display shows '000000 g' and is flanked by 'HI' and 'LO' indicators. Below the display are five small squares representing buttons, with a hand icon pointing to the fifth square from the left. An arrow points to the second state, where the display shows '000000 g' and is flanked by 'HI' and 'LO' indicators. Below the display are five small squares representing buttons, with the last digit '0' appearing to blink.

Press the key, and the process of "setting by entering values" is enabled with all digits displayed. Only the LSD blinks, indicating that it is the digit for value entry.

**9** Entering and setting of the upper limit value are over.

Change the digit for value entry. Enter a value to set.

Setting of the upper limit value is over. The display stays out while the value is being saved.

Weight display mode is resumed.

The diagram shows a sequence of four states. State 1: Display shows '00078.9 g' with 'HI' and 'LO' indicators. A hand icon points to the third digit '0'. State 2: Display shows '00678.9 g' with 'HI' and 'LO' indicators. A hand icon points to the second digit '6'. State 3: Display shows 'M' with 'HI' and 'LO' indicators. A hand icon points to the second button from the left. State 4: Display shows '678.9 g' with 'HI' and 'LO' indicators. A hand icon points to the second button from the left.

As in the case of entering the lower limit value, select the digit for value entry with the key and select a value to set with the key for entry of the upper limit value. When the entering of the upper limit value is over, press the key. The display disappears temporarily. When the upper limit value is saved, the display blinks.

**10** Setting is over.

Setting is over. Save the setting.

Weight display mode is resumed.

The diagram shows a sequence of three states. State 1: Display shows '678.9 g' with 'HI' and 'LO' indicators. Below the display are five small squares representing buttons, with a hand icon pointing to the second square from the left. An arrow points to State 2: Display shows 'PUSH 5.' with 'HI' and 'LO' indicators. Below the display are five small squares representing buttons, with a hand icon pointing to the second square from the left. An arrow points to State 3: Display shows '0.0 g' with 'HI' and 'LO' indicators. Below the display are five small squares representing buttons.

Press the key, and the set value is saved and "PUSH 5." is displayed. Press the key again, and the setting process is terminated and the weight display mode is resumed.

# Functions

This scale is provided with the functions shown in the table below. These functions can be adjusted according to your work conditions. ⇒ Refer to “Checking the Set Value” on page 29 and “Changing the Setting” on page 30.

## 1 Functions and How They Work

### 1-1 Basic Functions

\* Shaded parts indicate factory default settings.

Function	Display	How the function works			
Additional Function	15EL	0	OFF: Disables the function.		
		1	Enables the addition function.		
		2	Enables the limit function. ⇒ Refer to Section 2.2 “Details of the Limit Function.”		
Autozero (Zero tracking)	2 AD	0	OFF: Disables this function.		
		1	ON: Enables this function.		
Response Speed	3 RE	0	Display speed ↑ Fast ↓ Slow		
		1		* If “0” or “1” is set, the displayed values may flicker. * If the scale is influenced by wind or vibration, set “4” or “5.”	
		2			
		3			
		4			
5					
Stability Judgment	4 SD	1	Judgment precision ↑ Loose ↓ Strict		
		2		Judgment time ↑ Fast ↓ Slow	
		3			* This function indicates, by the status of unit display, whether the measurement is stable or unstable. * If the unit display is flickering, the measurement is unstable.
		4			
Autopower-off	5 AP	0	This function can be used only for the dry-cell battery type		
		1	OFF: Disables this function (for continuous use). ON: Turns off the power automatically when approximately 3 minutes have elapsed.		
Interface	5 IF	0	Reserved (Output is stopped.)		
		1	6-digit format		
		2	7-digit format		
External Taring	6 ET	1	Operation by contact inputs		
		2	Operation by commands input from a PC or other devices		
ON/OFF Key Control	7 PC	0	Disables the ON/OFF key.		
		1	Enables the ON/OFF key.		
GLP Compliance	8 GLP	0	Disables this function.		
		1	Enables this function.		
Span Adjustment	9 CR	0	Disables this function.		
		1	Calibration with an internal weight		
		2	Span test with an internal weight		
		3	Calibration with an external weight *2		
		4	Span test with an external weight		

## Functions

Function	Display	How the function works
minimum indication *1		10d ----- d

\* Shaded parts indicate factory default settings.

\* The functions from the Interface “5.1F.” to the GLP Compliance “8.0L P” and the Output Format of Actual Scale Interval “b.P r.F.” are not provided for the dry-cell battery type.

When you select the Additional Function “12EL 2,” the Interface “5.1F. 1” or “5.1F. 2”, or the GLP Compliance “8.0L P,” refer to the description on the next page.

\*1 GZH-(B)1500Ex,(B)3100Ex,(B)30KEx only.

### 1-2 Details of the Limit Function

When you select the Additional Function “15 E L. 2,” the following functional items are displayed before the Autozero function.

Functional item	Display		Description
Condition	11 E. a.	1	Always judge. (Judgment is also made when the scale is unstable.)
		2	Judge only when the scale is stable. (Judgment is not made when the scale is unstable.)
Range to Cover	12 L. i.	0	Do not detect when the limit is exceeded by 5 divisions or less (including the minus value).
		1	Do not detect when the limit is exceeded by 50 divisions or less (including the minus value).
		2	Detect both when the limit is exceeded and when it is not reached, including the minus value.
Judgment Type	13 P. n.	1	Set both the upper and lower limits.
		2	Set only the lower limit.
		3	Set only the upper limit.

\* Shaded parts indicate factory default settings.

### 1-3 Details of the Interface

When you select the Interface “5 1 F 1,” the process ends with “5 2. b. L.” and then the next function is displayed.

When you select the Interface “5 1 F 2,” the items up to “5 3 P R.” are displayed and then the next function is displayed.

Functional item	Display		Description
Output Control	5 1. a. c.	0	Stop output.
		1	Output continuously at all times. *1
		2	Output continuously if stable. (Stop output if unstable.) *1
		3	Output once when the  key is pressed.
		4	Output once when the scale is stable. Output when the sample is unloaded to cause the display to indicate a value below zero, and then another sample is placed to make the scale stable.
		5	Output once when the scale is stable. Stop output when unstable. Output once when the scale is stabilized again (the output includes zero) even if it is not reloaded.
		6	Output once when the scale is stable. Output continuously when unstable. Output is stopped after a single output when the scale is stable even if it is not reloaded.
Baud Rate	5 2. b. L.	1	1200 bps
		2	2400 bps
		3	4800 bps
Parity Bit	5 3 P R.	0	Reserved (Not set.)
		1	Odd parity
		2	Even parity

\* Shaded parts indicate factory default settings.

\*1: In continuous output mode, data is output at intervals of 0.1 to 1 second. (The interval changes depending on the weighing conditions and settings of other functions.)

## 1-4 Details of the GLP Compliance

When you select “*B.G.L.P. 1.*” the following functional items are displayed.

Functional item	Display		Description
Output of Calibration Results	<i>B 1.0.0.t.</i>	<i>0</i>	Stop output.
		<i>1</i>	Output the results.
GLP Compliance of Measurement Results	<i>B 2.0.d.</i>	<i>0</i>	Disable this function.
		<i>1</i>	Compliant.
Print Characters	<i>B 3.P.F.</i>	<i>1</i>	English
		<i>2</i>	Japanese (katakana)

\* Shaded parts indicate factory default settings.



## 2 Checking the Set Value

### 1 Call a function.

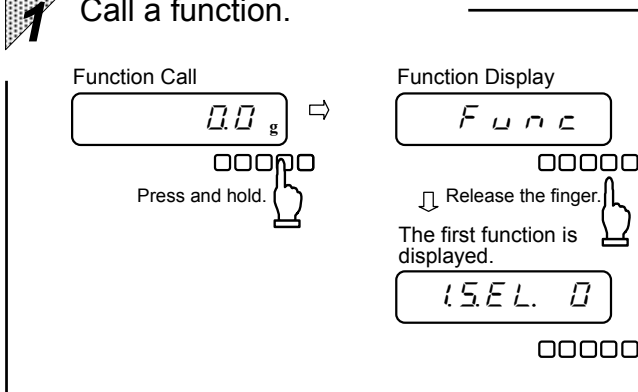



Press and hold the  key for approximately 4 seconds. When “Func” is displayed, release the finger.

Now the function setting mode is assumed and the first function “1SEL. 0” (Function Selection) is displayed.

⇒ For details, refer to pages 25 to 28.

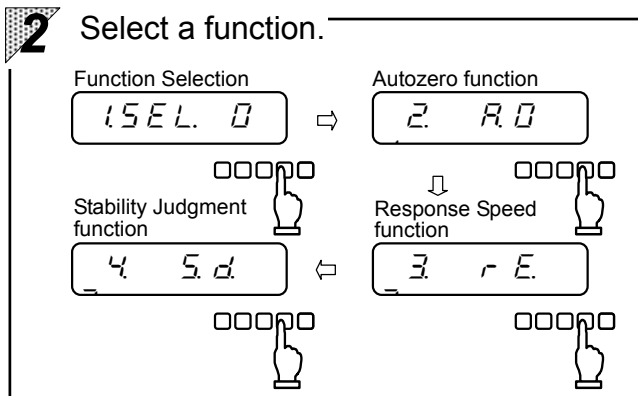
### 2 Select a function.





Press the  key, and the next function is displayed.

The next function is displayed each time the key is pressed.

⇒ For details, refer to pages 25 to 28.

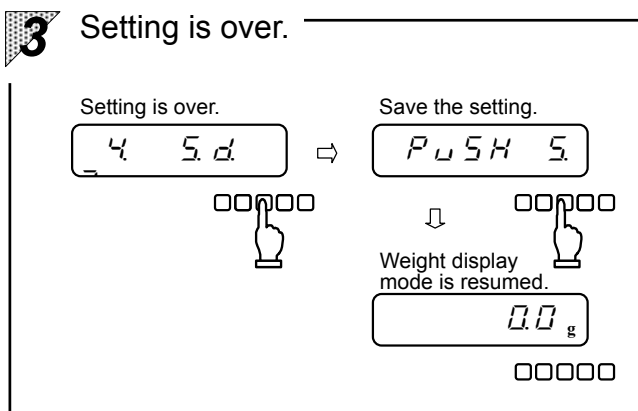
### 3 Setting is over.



Press the  key, and the setting is saved and “PUSH S.” is displayed.

Press the  key again, and the setting process is terminated and the weight display mode is resumed.

### 3 Change the Setting

**1** Call a function.

Function Call: 0.0 g

Function Display: Func

Press and hold.

Release the finger.

The first function is displayed.

1SEL. 0

Press and hold the  key for approximately 4 seconds. When “Func” is displayed, release the finger.

Now the function setting mode is assumed and the first function “1SEL. 0” (Function Selection) is displayed.

⇒ For details, refer to pages 25 to 28.

**2** Select a function.

Function Selection: 1SEL. 0

Autozero function: 2. RD 1

Stability Judgment function: 4. Sd 2

Response Speed function: 3. rE. 3

Press the  key, and the next function is displayed.

The next function is displayed each time the  key is pressed. Select the function whose setting you want to change.

⇒ For details, refer to pages 25 to 28.

**3** Change a setting.

Display the current setting: 4. Sd 2

Display the desired setting: 4. Sd 3

Press the  key, and the rightmost value changes. Then select the value that you want to set.

**4** Setting is over.

Setting is over: 4. Sd 3

Save the setting: PUSH 5

Weight display mode is resumed: 0.0 g

Press the  key, and the setting is saved and “PUSH 5” is displayed.

Press the  key again, and the setting process is terminated and the weight display mode is resumed.

# Calibration of the Scale

Check that the Span Adjustment function is set to calibration with an internal weight “CAL” (or set the Span Adjustment function to “CAL”). ⇒ Refer to “Checking the Set Value” on page 29 and “Changing the Setting” on page 30.

## 1 Calibration with an Internal Weight

**1** Call the Span Adjustment function.

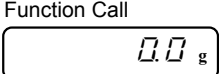
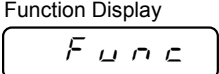
Function Call:  ⇒ 

Press and hold. 

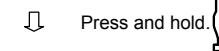
Function Display: 

Press and hold. 

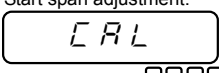
Start span adjustment. 

Release the finger. 

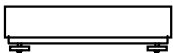

Press and hold the  key until the display changes from “Func” to “CAL” to enter the Span Adjustment mode. (This will take approximately 6 seconds.)

**2** Calibrate the zero point.

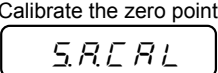
Check that nothing is placed on the scale. 

Calibrate the zero point. 



Check that nothing is placed on the pan. Press the  key while holding the  key down and then release the keys simultaneously. “S.CAL” is displayed and span adjustment is started.

**3** Setting of the zero point is over.

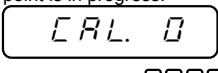
Calibration of the zero point is in progress. 

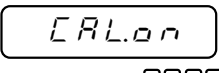
Calibrate the capacity point. 

“CAL. 0” now blinks in the display and the zero point is set automatically. When the setting of the zero point is over, “CAL. 0 n” is displayed.

**4** Calibrate the capacity point.

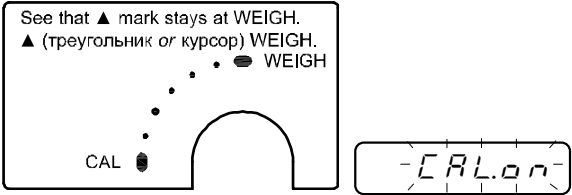
See that ▲ mark stays at WEIGH. ▲ (треугольник or курсор) WEIGH. 



Turn the calibration knob gently toward the “CAL” position until it stops. “CAL. 0 n” blinks in the display and the capacity point is calibrated automatically.

**5** Setting of the capacity point is over.

Save the span value.

When "PUSH S." is displayed, press the key. The display changes to "CALOFF." Turn the calibration knob toward the "WEIGH" position until you hear it click.

When "PUSH S." is displayed, press the key. The display changes to "CALOFF." Turn the calibration knob toward the "WEIGH" position until you hear it click.

**6** Span adjustment is over.

Span adjustment is over.

When the adjustment of the capacity point is over, the weight display mode is resumed after "End" is displayed, indicating that the span adjustment is completed.

When the adjustment of the capacity point is over, the weight display mode is resumed after "End" is displayed, indicating that the span adjustment is completed.

**Key points**

1. If you press the key first in step 2 where two keys should be pressed at a time, the process is discontinued.
2. Be careful that you do not touch the pan and that the scale is not influenced by wind or vibration during adjustment. If the scale is influenced by wind or vibration, the display may stall at blinking of "CALO."
3. If you want to discontinue the adjustment process, press the key. After "STOP" is displayed, the measurement mode is resumed.

## 2 Span Test with an Internal Weight

Check that the Span Adjustment function is set to span test with an internal weight “CAL 2” (or set the Span Adjustment function to “CAL 2”). ⇒ Refer to “Checking the Set Value” on page 29 and “Changing the Setting” on page 30.

**1** Call the span test.

Function Call  
00 g  
Press and hold.

Function Display  
Func  
Press and hold.

Start span adjustment.  
CAL  
Release the finger.

Press and hold the key until the display changes from “Func” to “CAL.” (This will take approximately 6 seconds.)

**2** Start the span test.

Check that nothing is placed on the scale.

Start the span test.  
t. int  
(2) (1)

Check that nothing is placed on the pan. Press the key while holding the key down and then release the keys simultaneously. “t. int” is displayed and a span test is started.

**3** Check the zero point.

Check the zero point.  
t. 0  
00000

Checking of the zero point is over.  
t. on  
00000

“t. 0” now blinks in the display and the zero point is set automatically. When the setting of the zero point is over, “t. on” is displayed.

**4** Check the capacity point.

See that ▲ mark stays at WEIGH.  
▲ (треугольник or курсор) WEIGH.

CAL

t. on  
00000

Turn the calibration knob gently toward the “CAL” position until it stops. “t. on” now blinks in the display and the zero point is checked automatically.

**5** Display the test result.

Display the test result.

The diagram shows two stages of the scale display. In the first stage, the display shows "d IFF." and below it are five empty boxes. An arrow points to the second stage, where the display shows "0.1 g" and below it are five empty boxes.

When checking of the capacity point is over, the test result is displayed in terms of weight after “d IFF.” is displayed.

**6** Checking of the capacity point is over.

Checking of the capacity point is over.

The diagram shows two stages of the scale display. In the first stage, the display shows "0.1 g" and below it are five empty boxes. An arrow points to the second stage, where the display shows "E R L. O F F." and below it are five empty boxes.

The display changes to “E R L. O F F.” Turn the calibration knob toward the “WEIGH” position until you hear it click.



**7** The span test is over.

The span test is over.

The diagram shows two stages of the scale display. In the first stage, the display shows "E n d" and below it are five empty boxes. An arrow points to the second stage, where the display shows "0.0 g" and below it are five empty boxes.

When checking of the capacity point is over, the weight display mode is resumed after “E n d” is displayed, indicating that the span test is completed.

**Key points**

1. If you press the  key first in step 2 where two keys should be pressed at a time, the process is discontinued.
2. Be careful that you do not touch the pan and that the scale is not influenced by wind or vibration during adjustment.  
If the scale is influenced by wind or vibration, the display may stall at blinking of “E. 0.”
3. If you want to discontinue the adjustment process, press the  key. After “S E T P” is displayed, the measurement mode is resumed.

### 3 Calibration with an External Weight

Check that the Span Adjustment function is set to calibration with an external weight “CAL 3” (or set the Span Adjustment function to “CAL 3”). ⇒ Refer to “Checking the Set Value” on page 29 and “Changing the Setting” on page 30.

**1** Call the Span Adjustment function.

Function Call

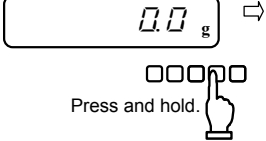

Function Display

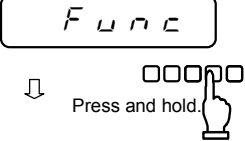

Start span adjustment.

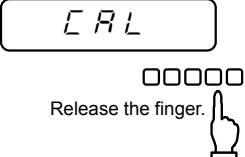

Press and hold the  key until the display changes from “Func” to “CAL.” (This will take approximately 6 seconds.)

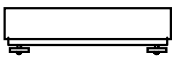

**2** Calibrate the zero point.

Check that nothing is placed on the scale.

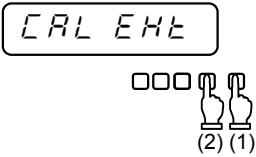

Start a span test.



Check that nothing is placed on the pan. Press the  key while holding the  key down and then release the keys simultaneously. “CAL EXT” is displayed and a span test is started.

**3** Setting of the zero point is over.

Calibration of the zero point is in progress.

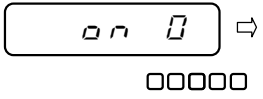

Checking of the zero point is completed.

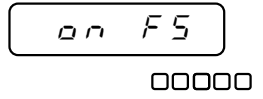

“on 0” now blinks in the display and the zero point is set automatically. When the setting of the zero point is over, “on FS” is displayed.

**4** Calibrate the capacity point.

Place a calibration weight on the scale.

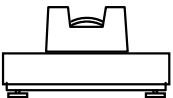

Start checking the capacity point.

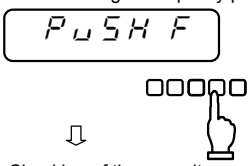

Checking of the capacity point is in progress.

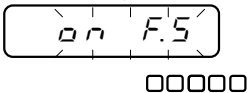

Gently place a calibration weight at the center of the pan. (When GZH-(B)30KEx is used, “PUSH F” is displayed at this time, so press the  key.) The display now blinks and the capacity point is checked.

**5** Setting of the capacity point is over.

Save the span value.

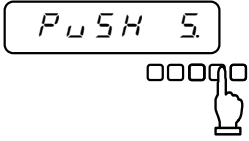

When “PUSH S.” is displayed, press the  key.

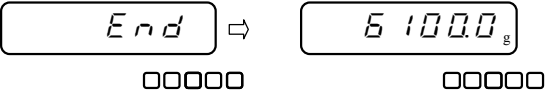

**6** The span test is over.

The span test is over.



When the adjustment of the capacity point is over, the weight display mode is resumed after “End” is displayed, indicating that the span adjustment is completed.

**Key points**

1. If you press the  key first in step 2 where two keys should be pressed at a time, the process is discontinued.
2. Be careful that you do not touch the pan and that the scale is not influenced by wind or vibration during adjustment.  
If the scale is influenced by wind or vibration, the display may stall at blinking of “On 0.”
3. If you want to discontinue the adjustment process, press the  key. After “St OP” is displayed, the measurement mode is resumed.
4. Calibration with an external weight is possible only when the lock switch is turned off.



## 4 Span Test with an External Weight

Check that the Span Adjustment function is set to span test with an external weight “CAL 4” (or set the Span Adjustment function to “CAL 4”). ⇒ Refer to “Checking the Set Value” on page 29 and “Changing the Setting” on page 30.

**1** Call a span test.

Function Call

Press and hold.

Function Display

Press and hold.

Start span adjustment.

Release the finger.



Press and hold the  key until the display changes from “Func” to “CAL.” (This will take approximately 6 seconds.)

**2** Start a span test.

Check that nothing is placed on the scale.

Start a span test.

(2) (1)

Check that nothing is placed on the pan. Press the  key while holding the  key down and then release the keys simultaneously. “t.EHt.” is displayed and a span test is started.

**3** Check the zero point.

Check the zero point.

Checking of the zero point is completed.

“on 0” now blinks in the display and the zero point is set automatically. When the setting of the zero point is over, “on FS” is displayed.

**4** Check the capacity point.

Place a calibration weight on the scale.

Start checking the capacity point.

Checking of the capacity point is in progress.

Gently place a calibration weight at the center of the pan. (When GZH-(B)30KEx is used, “PUSH H F.” is displayed at this time, so press the  key.) The display now blinks and the capacity point is checked.

**5** Display the test result.

Display the test result.



When checking of the capacity point is over, the test result is displayed in terms of weight after “d IFF.” is displayed.

**6** The span test is over.



The span test is over.

When checking of the capacity point is over, the weight display mode is resumed after “End” is displayed, indicating that the span test is completed. Unload the calibration weight.

**Key points**

1. If you press the  key first in step 2 where two keys should be pressed at a time, the process is discontinued.
2. Be careful that you do not touch the pan and that the scale is not influenced by wind or vibration during adjustment.  
If the scale is influenced by wind or vibration, the display may stall at blinking of “0.0 0.”
3. If you want to discontinue the adjustment process, press the  key. After “St OP” is displayed, the measurement mode is resumed.

# Troubleshooting

Symptom	Cause	Action to take
The limit function does not work.	<ul style="list-style-type: none"> <li>* The limit function is not selected.</li> <li>* A limit value is not entered.</li> <li>* The entered limit value is invalid.</li> </ul>	19P: Select the function. 23P: Perform the setting procedure. 23P: Check your operation.
The addition function does not work.	<ul style="list-style-type: none"> <li>* The addition function is not selected.</li> <li>* The sum mode is assumed.</li> </ul>	16P: Select the function. 17P: Check your operation.
The display does not light.	<ul style="list-style-type: none"> <li>* The power of the scale is turned off.</li> <li>⊙ Erroneous connection of the power cable</li> <li>○ The display was turned off by the autpower-off function.</li> </ul>	12P: Press the  key. 10P: Check the barrier connection. 25P: Press the  key.
The mark “  ” blinks.	<ul style="list-style-type: none"> <li>○ The battery power is weak. The mark blinks when the remaining time of the battery is about 6 hours.</li> </ul>	11P: Replace the batteries.
The display is slow to stabilize.	<ul style="list-style-type: none"> <li>* The scale is affected by wind or vibration.</li> <li>* The pan, tare, or the sample touches other objects.</li> <li>* The table under the scale is unstable.</li> </ul>	7P: Check the environment of the location. Or review the setting of the function.
Errors in measurement values	<ul style="list-style-type: none"> <li>* The taring operation is wrong.</li> <li>* The adjusters float, and the horizontal adjustment is not done correctly.</li> <li>* The displayed values changed after a long period of storage or when used in different locations.</li> </ul>	14P: Redo the taring. 9P: Check to make sure the scale is level. 31P: Calibrate the scale.
Weighing up to the weighing capacity is impossible. 0 - E r r is displayed.	<ul style="list-style-type: none"> <li>* The weight with tare exceeds the weighing capacity. Weighing range = tare weight + sample weight If the tare has no problem:</li> </ul>	14P: Recheck the tare. →: Breakage of the mechanical section!!
u - E r r is displayed.	<ul style="list-style-type: none"> <li>* The pan or the pan base is raised by other objects. If the pan and the pan base have no problem:</li> </ul>	15P: Check the surrounding conditions of the pan. →: Breakage of the mechanical section!!
b - E r r is displayed.	<ul style="list-style-type: none"> <li>* The scale is affected by static electricity or noise.</li> <li>* The electrical section of the scale is broken.</li> </ul>	→: Failure of the electrical section
E - E r r is displayed.	<ul style="list-style-type: none"> <li>* Addition was repeated twice. A negative number or zero was added.</li> </ul>	17P: Retry the addition.
1 - E r r is displayed.	<ul style="list-style-type: none"> <li>* If the standard weight is 40% of the weighing capacity or less (during adjustment or span tests by an external weight):</li> </ul>	35P: Retry span adjustment or span tests.
2 - E r r is displayed.	<ul style="list-style-type: none"> <li>* The scale is affected by wind or vibration during span adjustment.</li> </ul>	35P: Retry span adjustment.
3 - E r r is displayed.	<ul style="list-style-type: none"> <li>* The span adjustment or span test was conducted with the scale loaded with a sample.</li> </ul>	31P: Retry span adjustment or span tests.
4 - E r r is displayed.	<ul style="list-style-type: none"> <li>* The scale is affected by wind or vibration during span adjustment.</li> </ul>	31P: Retry span adjustment.

<Meaning of symbols>

- \*: Matters common to both types
- : Applies only to the dry-cell battery type.
- ⊙: Applies only to the power supply box type.

- 10P: The page to be referred to
- : Contact the retailer or a sales office or service representative of our company.

# Standard Specifications

## 1 Common Specifications

1. Explosion proof structure ..... Exia II BT4
2. Precision class ..... Class II
3. Measurement method ..... Dielectric system (tuning fork system)
4. Taring range ..... Up to weighing capacity
5. Display ..... LCD of up to 7 digits (character height = 17 mm, character width = 9 mm, with a 5-degree slant)
6. Calibration of the Scale ..... Semi-auto span adjustment
7. Display when overloaded ..... “ $\square - \bar{E} r r$ ” is displayed when the weighing capacity is exceeded by 9 divisions (over-error).
8. Operating temperature and humidity ..... Temperature: +5 to +35°C, Humidity: 80%rh or less
9. Power supply ..... Power supply box type: 230 VAC or 120VAC  
Dry-cell battery type: C-size manganese dry-cell battery  
(R14P(NR) National / Panasonic) ×6

### 10. Options

Printer output	For Shinko printers only
RS232C	D-sub 25 pin
RS422A	D-sub 25 pin
Limit output	12 pin terminals AC125 V, 0.4 A DC30 V, 2 A
Analog output	2 pin terminals DC5 V, 0.02 A
BCD output	36 pin terminals
<u>Remark:</u>	From above (1) through (4), two outputs are available to instal in one scale. However, the combination of RS232C and RS422A is unavailable.

### 11. Electrical Specifications

#### Power supply box specifications

Rating input voltage	AC230 V or AC120V
Rating input electric current	0.1 A
Frequency	50 Hz/60 Hz
Fuse specifications	

Rating input voltage	AC250 V
Rating input electric current	2 A
Type	Time lag

Please perform the exchange of the fuse after turning off power switch by all means.

Output terminal of the communication board (option ; Barrier type only)

## 2 Configuration of Each Model

### 2-1 Power Supply Box Type

Model	Weighing capacity/minimum measurable weight	Dimension of pan	Internal weight	Empty weight	Length of scale cable
GZH-610Ex	610 g/0.01 g	φ140	Available (manual)	Approx. 7.5 kg	1 m
GZH-1500Ex	1500 g/0.01 g	250 × 202		Approx. 9.6 kg	
GZH-3100Ex	3100 g/0.01 g				
GZH-6100Ex	6100 g/0.1 g	270 × 250		Approx. 17 kg	3 m
GZH-30KEEx	30000 g/0.1 g				

- \* The weight of the power supply box is excluded from the empty weight. (Weight of the power supply box: approx. 3.5 kg)
- \* The empty weight of the small model is the sum of the weights of the display section, measuring section, and pole.
- \* The empty weight of the medium and large models is the sum of the weights of the display section and measuring section.

### 2-2 Dry-Cell Battery Type

Model	Weighing capacity/minimum measurable weight	Dimension of pan	Internal weight	Empty weight	Length of scale cable
GZH-B610Ex	610 g/0.01 g	φ140	Available (manual)	Approx. 8.5 kg	1 m
GZH-B1500Ex	1500 g/0.01 g	250 × 202		Approx. 10.6 kg	
GZH-B3100Ex	3100 g/0.01 g				
GZH-B6100Ex	6100 g/0.1 g	270 × 250		Approx. 18 kg	3 m
GZH-B30KEEx	30000 g/0.1 g				

- \* The weight of the C-size manganese dry-cell batteries is included.
- \* The empty weight of the small model is the sum of the weights of the display section, measuring section, and pole.
- \* The empty weight of the medium and large models is the sum of the weights of the display section and measuring section

【Memo】



